

BIODEGRADATION OF CHLORPYRIFOS BY A MARINE BACTERIUM *Bacillus firmus* Strain BY6 ASSOCIATED WITH BRANCHING CORAL *Acropora* sp.

Agus Sabdono*^{1,2}

¹Department of Marine Science, Diponegoro University, Semarang – 50275, Central Java, Indonesia.

²Center for Tropical Coastal and Marine Studies, Diponegoro University, Widya Puraya, Semarang – 50275, Central Java, Indonesia.

Received : April, 21, 2006 ; Accepted : December, 15, 2006

ABSTRACT

A bacterium which utilizes chlorpyrifos as a sole source of carbon and energy was isolated from coral surface. The organism utilized chlorpyrifos up to 25 mg l⁻¹. The lag phase and time for degradation, however, were severely prolonged at chlorpyrifos concentrations above 10 mg l⁻¹. The growth kinetics of coral bacterium was studied in batch culture. Estimation of maximum growth rates (μ_{max}), obtained from turbidity measurements, was 0.14 h⁻¹ and half-saturation growth constant (C_s) was 9.34 mg l⁻¹ chlorpyrifos. This strain demonstrated greatest similarity to members of the order *Bacillales* and was closest to members of the *Bacillus firmus* group.

Keywords: coral bacterium, chlorpyrifos, growth kinetics, *Bacillus firmus*

* **Correspondence:** phone: +62-24-7474698; Fax: +62-24-7474698; email : agus_sabdono@yahoo.com

INTRODUCTION

Chlorpyrifos is an insecticide (kill or control insect) that has been one of the pesticides most used worldwide since 1965. Currently, over 850 registered chlorpyrifos products are on the market (Anonymous, 2002). Contamination of soil by the pesticide may occasionally lead to the contamination of surface and groundwater (Anonymous, 1998). Reports from the Environmental Protection Agency (1997) suggest that a wide range of water and terrestrial ecosystems may be contaminated with chlorpyrifos. A single application of chlorpyrifos poses risks to small mammals,

birds, fish and aquatic invertebrate species (Anonymous, 2002). Sabdono *et al.* (2007) reported that chlorpyrifos residue was detected in stress or dead coral tissues of Java Sea, Indonesia.

Chlorpyrifos [*O,O*-diethyl *O*-(3,5,6-trichloro-2-pyridyl) phosphorothioate] is used worldwide as an agricultural insecticide and household pest. Its environmental fate has been studied extensively, and the reported half-life in soil varies from 10 to 120 days, with 3, 5, 6-trichloro-2-pyridinol (TCP) as the major degradation product (Singh *et al.*, 2003; Racke *et al.*, 1988). Chlorpyrifos is characterized by a P-O-C linkage as in other organophosphate pesticides, such as diazinon,

parathion, methylparathion, and fenitrothion. Unlike in the case of other organophosphates, however, there have been no reports of enhanced degradation of chlorpyrifos since its first use in 1965 (Singh *et al.*, 2003). It has been suggested that the accumulation of TCP, which has antimicrobial properties, prevents the proliferation of chlorpyrifos-degrading microorganisms in soil (Racke *et al.*, 1990).

The important role of microorganisms in the degradation of organic pollutant is clearly understood. Eventhough the microorganism is capable of degradation of organic pollutants and their catabolic pathways have been studied intensively, information on the microbial degradation of organophosphate in marine environments is still very limited. To date, there have been no reports on accelerated biodegradation of chlorpyrifos by marine bacteria. In most of the studies chlorpyrifos has been reported to be degraded by soil bacteria, such as *Escherichia coli* (Wang *et al.*, 2002), *Arthrobacter* sp. (Mallick, *et al.*, 1999) *Agrobacterium* sp. (Horne *et al.*, 2002) and *Enterobacter asburiae* (Singh *et al.*, 2004).

The molecular study of degradation of certain organophosphates has been carried out widely. Various organophosphate-degrading genes (*opd* genes) have been isolated from different species, some of which could degrade chlorpyrifos (Horne *et al.*, 2002; Mulbry *et al.*, 1986; Richnis *et al.*, 1997; Serdar *et al.*, 1982). In many studies, *opd* genes were found to be plasmid based

and had similar DNA sequences. However, Horne *et al.* (2002) isolated an *opd* gene from *Agrobacterium radiobacter*, which was located on the chromosome but had a similar sequence to the *opd* gene from other bacteria.

The experiments reported here were carried out to isolate a chlorpyrifos-mineralizing bacterium from the coral tissues, characterize chlorpyrifos-degrading isolate, and study the kinetic growth and chlorpyrifos degradation of isolate.

MATERIALS AND METHODS

Sampling and isolation of coral-associated bacteria

The coral was collected from Teluk Awur (06°37'02,5" N; 110°38'21,4" E), North Java Sea, Indonesia (Fig.1) by scuba diving and identified as *Acropora* sp. according to Veron (1986). Upon collection coral fragments were put into sterile plastic bags (Whirl-Pak, Nasco, USA) and immediately brought to the Marine Station of the Diponegoro University where they were rinsed with sterile seawater and scraped off with a sterile knife. The resultant tissues were serially diluted, spread on ½ strength ZoBell 2216E marine agar medium and incubated at room temperature for 48 hours. On the basis of morphological features, colonies were randomly picked and purified by making streak plates (Madigan *et al.*, 2000).

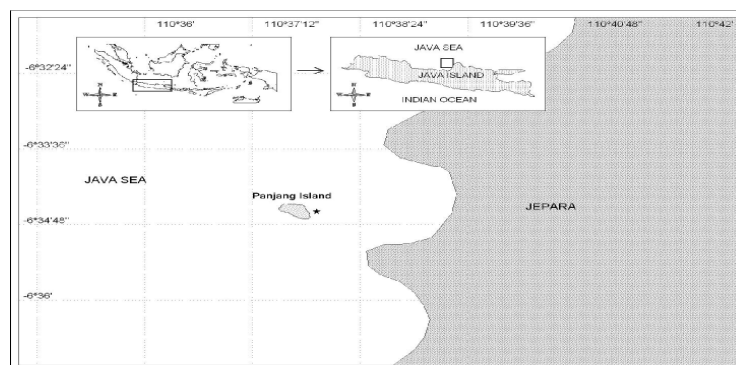

Fig. 1. Sampling site for the collection of coral from Teluk Awur waters, Jepara

Screening of chlorpyrifos-degrading coral bacteria

Experiments were conducted by using 50-ml erlenmeyer flasks containing 15 ml of 10 mg l⁻¹ chlorpyrifos in Zobell 2216E medium. Flasks were inoculated with approximately 0.25 µg (dry weight) of strain and incubated at room temperature on a rotary shaker at 120 rpm for 48 h. Samples of culture (1 ml) were removed and centrifuged in a microcentrifuge (Microfuge 11; Beckman Instruments, Inc., Fullerton, Calif.) at 12,000 rpm for 2 min, and supernatant was decanted into eppendorf. Samples were analyzed immediately or were refrigerated until analysis.

Growth analyses

Biomass concentrations were measured by spectrophotometry at 600 nm using a dry weight calibration curve. A fluorometer (Turner Model III) with a 10-mm square cuvette was used. Controls were run using medium made with double-distilled water with no carbon source to insure that the growth observed was not due to organic contamination present in the ordinary distilled water.

GC-MS analyses

After extractions, the samples were then analyzed by gas chromatograph Model Hitachi 163 FPD (Flame Photometer Detector), and nitrogen high pure (HP) was used as the carrier gas. A 1 meter glass column (3 mm ID) packed with 10% Silikon DC200 on 80-100 mesh Supelcon was used. Gasflow at 50 ml /min, column temperature at 200 °C, detector temperature at 230 °C and the injector temperature at 230 °C were maintained.

Bacterial strain

A coral bacterium strain BY6 was used in this study. This strain was selected based on the best growth and degradation among coral isolates. This strain was grown at room temperature in Zobell 2216E medium supplemented with 10 mg l⁻¹ chlorpyrifos.

Degradation of chlorpyrifos by isolate BY6

Experiments were conducted by using 250-ml erlenmeyer flasks containing 100 ml of 5, 10, 15, 20, and 25 mg l⁻¹ chlorpyrifos in Zobell 2216E medium. Flasks were inoculated with approximately 0.25 µg (dry weight) of strain and incubated at room temperature on a rotary shaker at 120 rpm. Samples of culture (1 ml) were removed periodically and centrifuged in a microcentrifuge (Microfuge 11; Beckman Instruments, Inc., Fullerton, Calif.) at 12,000 rpm for 2 min, and supernatant was decanted into eppendorf. Samples were analyzed immediately or were fixed with 10 µl of 40% H₂SO₄ and refrigerated until analysis.

DNA extraction, PCR amplification and sequencing of 16S rRNA gene fragments

DNA extraction, PCR amplification of partial 16S rRNA gene of bacterial strain, purification of PCR product and subsequent sequencing analysis was performed according to the method of Radjasa *et al.* (2007). The determined DNA sequence of strain was then compared for homology to the BLAST database. Phylogenetic tree was constructed by using.

Phylogenetic analysis.

A phylogenetic tree was constructed using maximum-likelihood analysis. Alignment positions at which less than 50 % of sequences of the entire set of data had the same residues were excluded from the calculations to prevent uncertain alignments within highly variable positions of the 16S rDNA. CLUSTAL X was used for multiple alignment/pairwise of the DNA sequence (Thompson *et al.*, 1997). Phylogenetic analysis was performed with the PAUP*4.0 (Phylogenetic Analysis Using Parsimony) software package (Swofford, 1998).

RESULTS AND DISCUSSION

Chlorpyrifos Degradation by Isolate BY6

Chlorpyrifos degradation of the five concentrations showed distinct patterns (Fig.2). Strain BY5 degraded 25 mg l⁻¹

chlorpyrifos rapidly. In this concentration approximately 50% of applied chlorpyrifos was degraded after 20 hours, following which there was a period of rapid loss, with almost constant degradation after 32 hours. Similarly, approximately 75-80% of the 5, 10, 15 and 20 mg l⁻¹ chlorpyrifos concentration had been degraded in medium after 24 hours. The bacterium isolated in this present research was not so strong in its degradable ability. Singh *et al.* (2004) reported that *Enterobacter* Strain B-14 hydrolyzed 35 mg l⁻¹ concentration of chlorpyrifos within 24 h. So far, strain BY6 is the first strain of coral bacterium reported to be able to degrade chlorpyrifos. It was not a surprise that this bacterium could not degrade chlorpyrifos completely. It seems that cooperative metabolic activities in bacteria of different cultures are needed to degrade chlorpyrifos. Mallick *et al.* (1999) and Wang *et al.* (2002) reported that chlorpyrifos was to be degraded cometabolically in liquid media by *Flavobacterium* sp. and also by an *Escherichia coli* clone with *opd* gene.

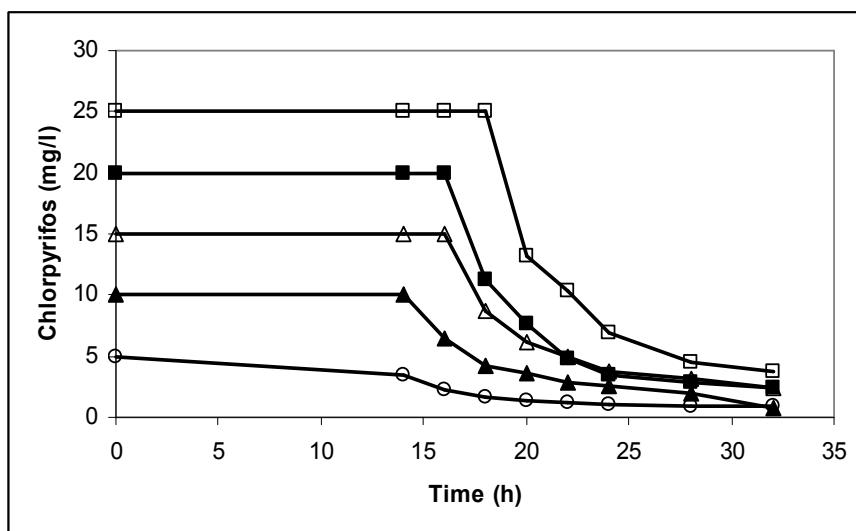

Fig. 2. Chlorpyrifos degradation of the five different concentrations (Symbols: □: 5 mg/l, ■: 10 ppm, △: 15 ppm, ▲: 20 ppm, ○: 75 ppm ppm chlorpyrifos)

Cell growth and substrate utilization

The relationship of concentration of chlorpyrifos to growth rate strain BY6 was determined by using batch culture methods. Values of specific growth rate (μ) obtained from turbidity measurements ranged from 0.0509 h^{-1} to 0.0877 h^{-1} . Furthermore, the

highest growth rate of 0.0877 h^{-1} occurred at 20 mg l^{-1} chlorpyrifos. Above this level, growth was strongly inhibited. As shown in Fig. 3, the estimate of half-saturation growth constant (C_s) was 9.34 ppm chlorpyrifos and the maximum growth rates (μ_{max}) were 0.14 h^{-1} . No report could be compared with this kinetic result.

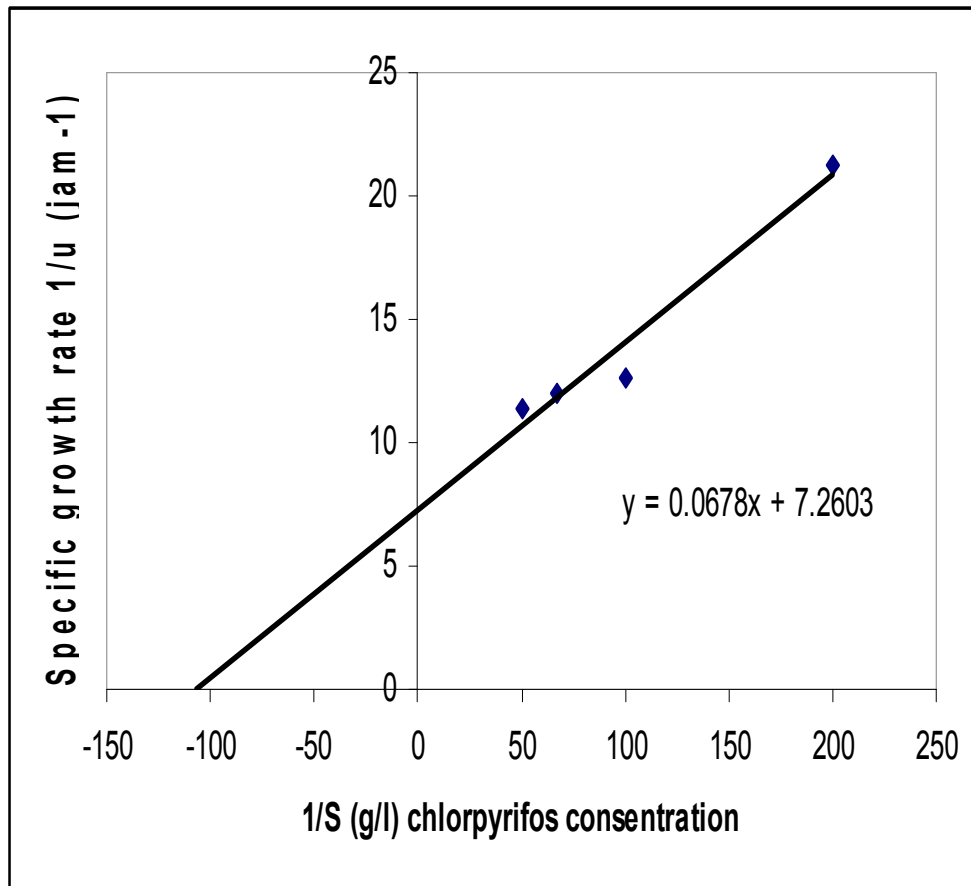

Fig. 3. Specific growth rate of coral bacterium Strain BY6 at various concentration of chlorpyrifos

Batch cultures of the coral bacterium strain BY6 on chlorpyrifos demonstrated interesting results. The lag growth rate was seen to be reduced by the presence of higher concentration of chlorpyrifos (Fig 4). Tyler

and Finn (1974) stated that the duration of lag phase depended on substrate concentration and on adaption of the inoculum. In addition, the finite lag phase as predicted by extrapolation of the curves to

zero concentration could be due to osmotic shock. Dapaah and Hill (1992) stated that frequently the lag phase is simply modelled by a pure time delay where nothing is assumed to happen. However, microbial cell fabricates new enzymes and ribosomes to be

used in their exponential growth and metabolic pathway (Freifelder, 1987). Furthermore, Esener *et al.* (1982) demonstrated that the RNA content of *Klebsiella pneumoniae* increases with a specific growth rate.

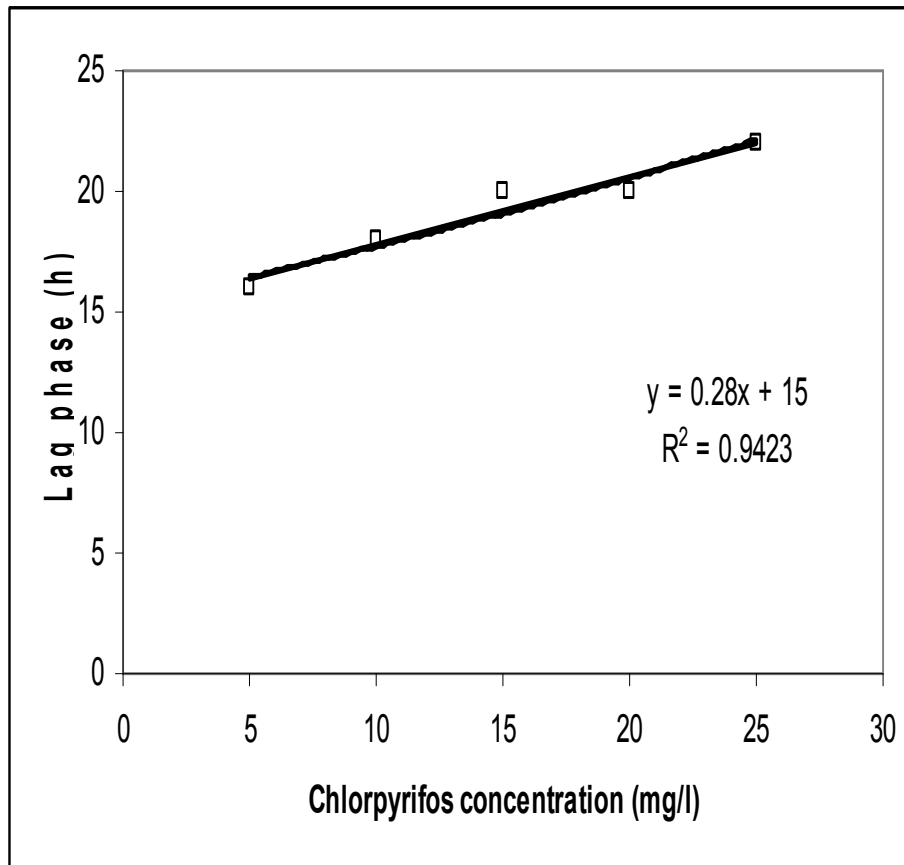

Fig. 4. Effect of adaption on the lag phase at various concentrations of chlorpyrifos

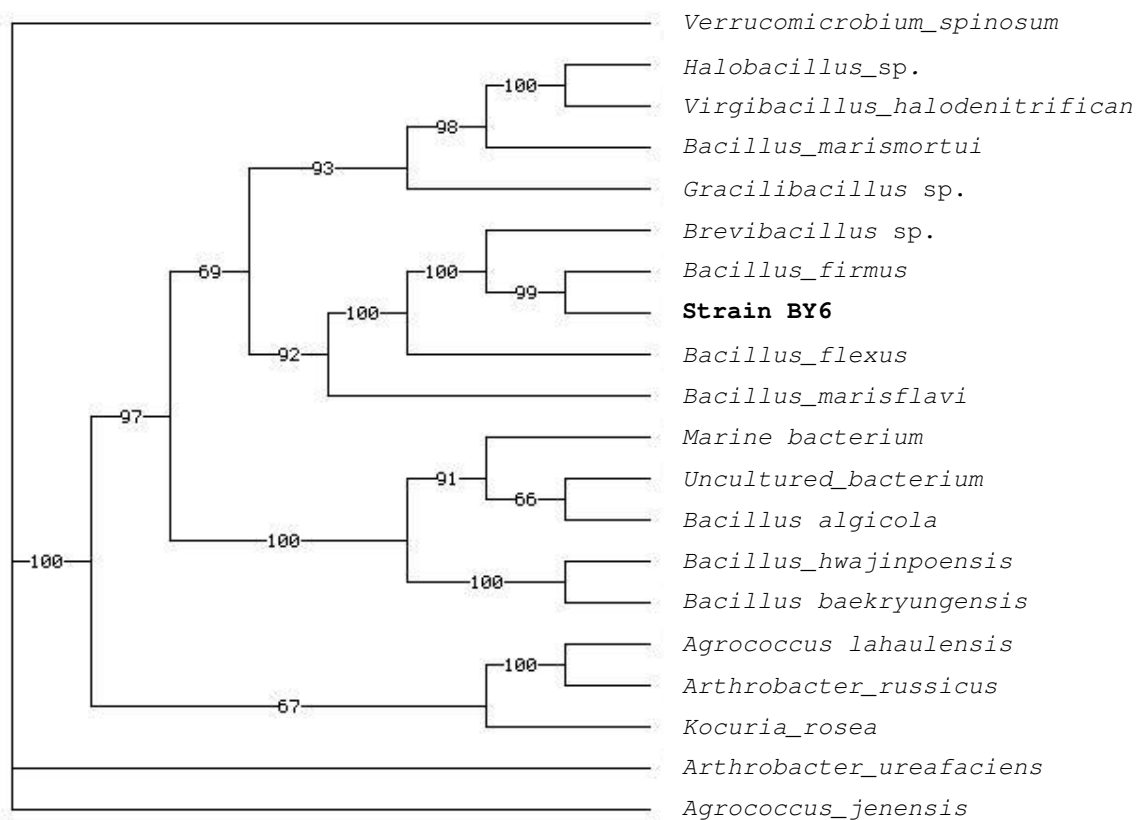

Fig. 5. Phylogenetic tree based on comparative 16S rRNA gene sequence analysis of *Bacillus* species showing the phylogenetic affiliation of strain BY6. *Verrucomicrobium spinosum* was used as outgroup. The bar indicates 2% sequence divergence.

Phylogenetic analysis

A comparison of the 16S rRNA gene sequence of strain BY6 with sequences from GenBank demonstrated that this strain is affiliated to the family *Bacillus* within the order *Bacillales*. The phylogenetic tree showed that isolate BY6 is most closely related with *Bacillus firmus* with a homology of 96 %. Different species have been reported to degrade chlorpyrifos, such as, *Escherichia coli* (Wang *et al.*, 2002), *Arthrobacter* sp. (Mallick, *et al.*, 1999) *Agrobacterium* sp. (Horne *et al.*, 2002) and *Enterobacter asburiae* (Singh *et al.*, 2004). However, this is the first report of

chlorpyrifos degradation by a *Bacillus* species.

CONCLUSION

The results of this investigation indicate that the use of coral bacteria to deplete chlorpyrifos in contaminated marine sites is potential. The degradation rate of chlorpyrifos strongly relates to chlorpyrifos concentration, characterizing the pathway for degradation and identifying the genes and enzymes involved in this process representing areas for further investigation.

ACKNOWLEDGEMENTS

Sincere thank is addressed to Dr. Ocky Karna Radjasa and his team for their technical assistance. This research was supported by International Environment Research Center, UNU-GIST, Gwangju, Korea.

REFERENCES

- Anonymous, 2002. *Chlorpyrifos Facts*. EPA 738-F-01-006.
- Anonymous, 1998. Fact sheet: chlorpyrifos. *Pestic. News* 41: 18-19.
- Environmental Protection Agency. 1997. *Review of chlorpyrifos poisoning data*. EPA, Washington, DC.
- Dapaah, S.Y. and G.A. Hill 1992. Biodegradation of chlorophenol mixtures by *Pseudomonas putida*. *Biotechnol. Bioeng.* 40: 1353-1358.
- Esener, A.A., T. Veerman, J.A. Roels, and N.W.F. Kossen 1982. Modelling of bacterial growth : formulation and evaluation of a structured model. *Biotechnol. Bioeng.* 24: 1749-1764.
- Freifelder, D.M. 1987. *Microbial genetics*. Jones and Bartlett Publisher, Inc.
- Horne, I., T. D. Sutherland, R. L. Harcourt, R. J. Russell, and J. G. Oakeshott. 2002. Identification of an *opd* (organophosphate degradation) gene in an *Agrobacterium* isolate. *Appl. Environ. Microbiol.* 68:3371-3376
- Madigan M.T, J.M. Martinko, J. Parker, and T.D. Brock, 2000. *Biology of microorganisms*. Prentice-Hall, Inc., New Jersey, USA
- Mallick, B. K., A. Banerji, N. A. Shakil, and N. N. Sethunathan. 1999. Bacterial degradation of chlorpyrifos in pure culture and in soil. *Bull. Environ. Contam. Toxicol.* 62:48-55
- Mulbry, W. W., J. S. Karns, P. C. Kearney, J. O. Nelson, and J. R. Wild. 1986. Identification of a plasmid-borne parathion hydrolase gene from *Flavobacterium* sp. by southern hybridization with *opd* from *Pseudomonas diminuta*. *Appl. Environ. Microbiol.* 51:926-930.
- Racke, K. D., J. R. Coats, and K. R. Titus. 1988. Degradation of chlorpyrifos and its hydrolysis products, 3,5,6-trichloro-2-pyridinol, in soil. *J. Environ. Sci. Health* 23:527-539.
- Racke, K. D., D. A. Laskowski, and M. R. Schultz. 1990. Resistance of chlorpyrifos to enhanced biodegradation in soil. *J. Agric. Food Chem.* 38:1430-1436.
- Radjasa, O.K., T. Martens, H.P. Grossart, T. Brinkoff, A. Sabdono and M. Simon 2007. Antagonistic activity of a marine bacterium *Pseudoalteromonas luteoviolacea* TAB4.2 associated with coral *Acropora* sp. *J. Biol. Sci.* 7:239-246.
- Richnis, R., I. Kaneva, A. Mulchandani, and W. Chen. 1997. Biodegradation of organophosphorus pesticides using surface-expressed organophosphorus hydrolase. *Nat. Biotechnol.* 15:984-987.
- Sabdono, A., S. Kang, H.G. Hur, H.P. Grossart, M. Simon and O.K. Radjasa. 2007. Organophosphate Pesticide Concentration in Coral Tissues of Indonesian Coastal Waters. *Pak. J. Biol. Sci.* 10 (11): 1926-1929.
- Serdar, C. M., D. T. Gibson, D. M. Munnecke, and J. H. Lancaster. 1982. Plasmid involvement in parathion hydrolysis by *Pseudomonas diminuta*. *Appl. Environ. Microbiol.* 44:246-249.

- Singh, B. K., A. Walker, J. A. W. Morgan, and D. J. Wright. 2003. Effect of soil pH on the biodegradation of chlorpyrifos and isolation of a chlorpyrifosdegrading bacterium. *Appl. Environ. Microbiol.* 69:5198–5206.
- Singh, B. K., Walker, A., Morgan, J. A. W., Wright, D. J. (2004). Biodegradation of Chlorpyrifos by Enterobacter Strain B-14 and Its Use in Bioremediation of Contaminated Soils. *Appl. Environ. Microbiol.* 70: 4855-4863
- Swofford, D. L. 1998. PAUP*. Phylogenetic Analysis Using Parsimony (*and Other Methods). Version 4. Sinauer Associates, Sunderland, Massachusetts. Copyright © Smithsonian Institution, 1998
- Thompson, J.D., T.J. Gibson, F. Plewniak, F. Jeanmougi, and D.G. Higgins. 1997. The Clustal X-Window interface: Flexible strategies for multiple alignment through sequence alignment aided by quality analysis tools. *Nucl. Acids Res.* 25: 4876-4882.
- Tyler, J.E. and R.K. Finn 1974. Growth rates of a Pseudomonad on 2,4-Dichlorophenxy -acetic acid and 2,4-Dichlorophenol. *Appl. Microbiol.* 28 (2): 181-184.
- Veron J.E.N, 1986. Corals of Australia and the Indo-Pacific. University of Hawaii, Honolulu
- Wang, A. A., A. Mulchandani, and W. Chen. 2002. Specific adhesion to cellulose and hydrolysis of organophosphate nerve agents by a genetically engineered *Escherichia coli* strain with a surface-expressed cellulose-binding domain and organophosphorus hydrolase. *Appl. Environ. Microbiol.* 68:1684–1689.