

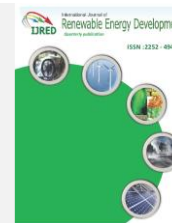

Contents list available at IJRED website

Int. Journal of Renewable Energy Development (IJRED)

Journal homepage: <http://ejournal.undip.ac.id/index.php/ijred>



A Novel Global MPP Tracking of Photovoltaic System based on Whale Optimization Algorithm

C.H. Santhan Kumar* and R. Srinivasa Rao

Department of Electrical and Electronics Engineering, JNT University Kakinada, Kakinada, Andhra Pradesh 533003, India

ABSTRACT. To harvest maximum amount of solar energy and to attain higher efficiency, photovoltaic generation (PVG) systems are to be operated at their maximum power point (MPP) under both variable climatic and partial shaded condition (PSC). From literature most of conventional MPP tracking (MPPT) methods are able to guarantee MPP successfully under uniform shading condition but fails to get global MPP as they may trap at local MPP under PSC, which adversely deteriorates the efficiency of Photovoltaic Generation (PVG) system. In this paper, a novel MPPT based on Whale Optimization Algorithm (WOA) is proposed to analyze analytic modeling of PV system considering both series and shunt resistances for MPP tracking under PSC. The proposed algorithm is tested on 6S, 3S2P and 2S3P Photovoltaic array configurations for different shading patterns and results are presented. To compare the performance, GWO and PSO MPPT algorithms are also simulated and results are also presented. From the results, it is noticed that proposed MPPT method is superior to other MPPT methods with reference to accuracy and tracking speed.

Keywords: Maximum power point tracking, Partial shaded condition, Photovoltaic generation system, Single diode model, Whale optimization algorithm.

Article History: Received July 23rd 2016; Received in revised form September 15th 2016; Accepted October 1st 2016; Available online

How to Cite This Article: Kumar, C.H.S and Rao, R.S. (2016) A Novel Global MPP Tracking of Photovoltaic System based on Whale Optimization Algorithm. Int. Journal of Renewable Energy Development, 5(3), 225-232.
<http://dx.doi.org/10.14710/ijred.5.3.225-232>

1. Introduction

Due to dearth of fossil fuels and escalate load demand, renewable energy plays a crucial role in future power generation. Photovoltaic generation system is a popular renewable energy source which is inexhaustible and available in most regions of the world and proved to be a reasonably priced source of energy. To harvest maximum amount of solar energy, PVG systems are forced to operate at maximum power point (MPP) under both variable climatic and partial shaded condition (PSC) in conjunction with a power electronic converter. When PVG systems are subjected to uniform irradiation condition conventional MPPT controllers can efficiently track MPP (Kamarzaman *et al.* 2014, Reisi *et al.* 2013). But, when PVG system is subjected to PSC (due to passing clouds, tree branches, building shadows, etc.), its current-voltage (I-V) and power-

voltage (P-V) characteristics exhibits many local maximum power points (LMPP) and only one global maximum power point (GMPP) due to bypass diode operation across the shaded modules (Silvestre *et al.* 2009). Many of the conventional MPPT algorithms cannot differentiate between LMPP and GMPP and thus they trap at one of the LMPP which adversely deteriorates the efficiency of PVG systems (Ishaque *et al.* 2013).

Several researchers proposed various soft computing based MPPT algorithms (Salam *et al.* 2013). Out of which meta-heuristic optimization algorithm based MPPT techniques like Particle Swarm Optimization (PSO) (Ishaque *et al.* 2012 – Liu *et al.* 2012), Artificial Bee Colony (ABC) (Benyoucef *et al.* 2015, Sundareswaran *et al.* 2015), Ant Colony Optimization (ACO) (Jiang *et al.* 2013), Differential Evolution (DE) (Tajuddin *et al.* 2013), Cuckoo Search

*Corresponding Author: +919885554065; Fax : 08847772000
Email: wizitesk@gmail.com

(CS) (Ahmed *et al.* 2014), Genetic Algorithms (GA) (Daraban *et al.* 2014), Flashing Firefly (FF) (Sundareswaran *et al.* 2014) and Grey Wolf Optimizer (GWO) (Satyajit *et al.* 2016) have growing interest due to their adaptability for system hardware implementation. These MPPT techniques alter noticeably in terms of accuracy, efficiency, tracking speed, cost, complexity and flexibility (Liu *et al.* 2015, Ahmed *et al.* 2015). Decision variables like voltage, duty ratio and current are taken as population of particles (candidate solutions) to find the maximized solution of power subjected to PSC, where PV output power is taken as objective function to be maximized.

Among these techniques, most of the authors extensively used PSO method for GMPP tracking under PSC. But it has some drawbacks like larger settling time, power oscillations, local maximum trapping and larger regions of exploration. Therefore, it is vital to develop a new and ameliorate MPPT algorithm for faster convergence to GMPP of PVG system under PSC. Recently, Whale optimization algorithm (WOA) was developed by (Mirjalili *et al.* 2016). WOA is inspired from a special hunting behavior of humpback whales and it can be successfully applied for non-linear optimization problems. In this paper, WOA is applied for MPP tracking of PVG systems subjected to PSC.

The rest of the paper is organized as follows: Modeling of PVG system under PSC is discussed in section 2. Section 3 briefly introduces WOA and its application for MPPT problem followed by results and comparison between WOA, GWO and PSO MPPT algorithms in Section 4, followed by conclusion in Section 5.

2. Modeling of PV system under PSC

2.1 PV module

Several mathematical models of photovoltaic (PV) cell are proposed by researchers, out of which single diode model (SDM) is more predominantly used for PV cell modeling due to its simplicity and computational efficiency (Ma *et al.* 2014). The single diode model of PV module is presented in Fig. 1.

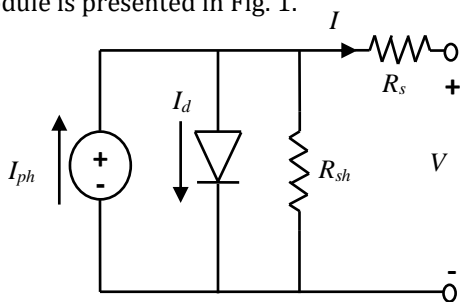

Fig. 1 Single diode model of module

The PV output current for the circuit shown in Fig. 1 is defined as

$$I = I_{ph} - I_o \left[\exp \left(\frac{V + IR_s}{V_t} \right) - 1 \right] - \frac{V + IR_s}{R_{sh}} \quad (1)$$

where I is PV output current, I_{ph} is the Photo current of module, I_o is the Diode saturation current, V is PV output voltage, R_s and R_{sh} are the series and shunt resistances.

$$V_t = \frac{N_s K T A}{q} \quad (2)$$

$$I_{ph} = \left(I_{sc_stc} + k_i \Delta T \right) G \quad (3)$$

where V_t is the thermal voltage of PV module, N_s is Number of cells in series in a module, q is the Charge of an electron (1.6×10^{-19} C), A is the Diode ideality factor, K is the Boltzmann's constant (1.38×10^{-23} N-m/K), T is the Panel operating temperature (in Kelvin), I_{sc_stc} is the short circuit current at standard test conditions (STC), k_i is the current temperature coefficient, ΔT is the temperature change ($\Delta T = T - T_{stc}$) in Kelvin and G is the solar irradiation in kW/m².

$$I_o = I_{o_stc} \left(\frac{T_{stc}}{T} \right)^3 \exp \left[\frac{q E_g}{AK} \left(\frac{1}{T_{stc}} - \frac{1}{T} \right) \right] \quad (4)$$

$$I_{o_stc} = \frac{I_{sc}}{\exp \left(\frac{q V_{oc}}{N_s AK T_{stc}} \right) - 1} \quad (5)$$

where E_g is the bandgap energy (eV), V_{oc} is the open circuit voltage and I_{sc} is the short circuit current of PV module.

Equation (1) in terms of voltage function can be represented as:

$$f(V, I) = V - I_{ph} R_{sh} + I_o R_{sh} \left(\exp \left(\frac{V + IR_s}{V_t} \right) - 1 \right) + I (R_s + R_{sh}) \quad (6)$$

Equation (6) is non-linear with two variables V, I can be solved by Newton's iterative method. The PV module parameters used for modeling the PV system are given in Table 1.

Tabel 1
Parameters of Kyocera KC-200GT module

Maximum power (P_{mp})	200 W
Open circuit voltage (V_{oc})	32.9 V
Short circuit current (I_{sc})	8.21 A
Maximum power Voltage (V_{mp})	26.3 V
Maximum power current (I_{mp})	7.61 A
Voltage temperature coefficient (k_v)	-1.23×10^{-1} V/°C
Current temperature coefficient (k_i)	3.18×10^{-3} A/°C

2.2 PSC Modeling

In this work a system with 6S (Six series), 3S2P (Three series two parallel) and 2S3P (Two series three parallel) PV configurations as shown in Fig. 2 are modeled using the following equations:

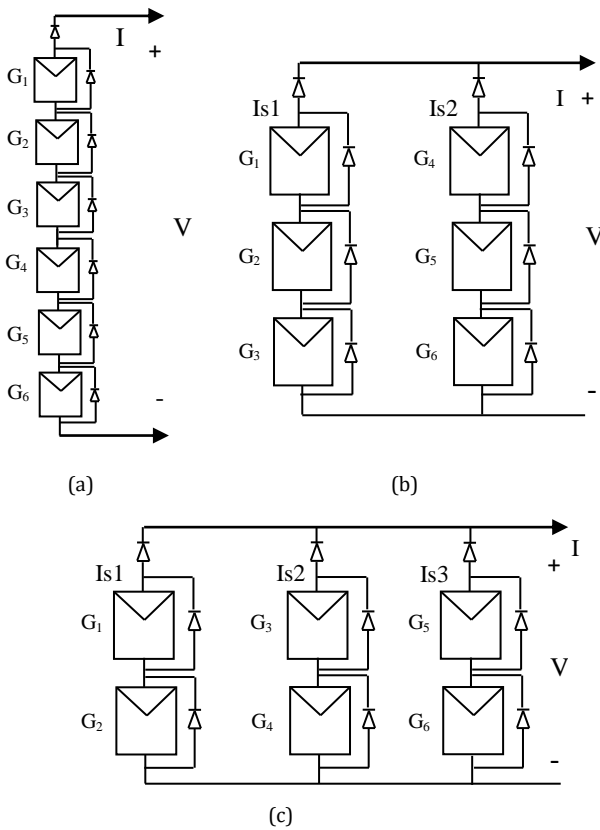

Fig. 2 (a) 6S PV configuration (b) 3S2P PV configuration

Output voltage of n^{th} module with both series and shunt resistance is obtained by comparing photo current of n^{th} module with corresponding string current I_s^k as follows:

$$V^{kn} = \begin{cases} V - I_{ph}^{kn} R_{sh} + I_o R_{sh} \left(e^{\left(\frac{V^{kn} + I R_s}{V_t} \right)} - 1 \right) \\ + I_s^k (R_s + R_p), & I^{kn} > I_s^k \\ 0 & I^{kn} \leq I_s^k \end{cases} \quad (7)$$

where V^{kn} is voltage across the n^{th} module of k^{th} string by varying the current in the string, I_s from zero to photocurrent of the module with greater irradiation. The output voltage of k^{th} string is obtained by

$$V_s^k = \sum_{n=1}^m V^{kn} \quad (8)$$

where m is the number of modules in a string, PV Output current of the array is given by

$$I = \sum_{k=1}^s I_s^k \quad (9)$$

where s is number of parallel connected strings in an array. For detailed explanation refer (Alajmi *et al.* 2013).

3. WOA and its application for MPPT

3.1 Overview of WOA

Whale optimization algorithm is inspired from bubble net hunting strategy of humpback whales proposed by (Mirjalili *et al.* 2016). Humpback whale is the biggest of all whales and it has special hunting mechanism of spiral bubble-net feeding. These whales hunt the school of fishes or krill's on the surface by creating distinctive bubbles in circular path as depicted in Fig. 3.

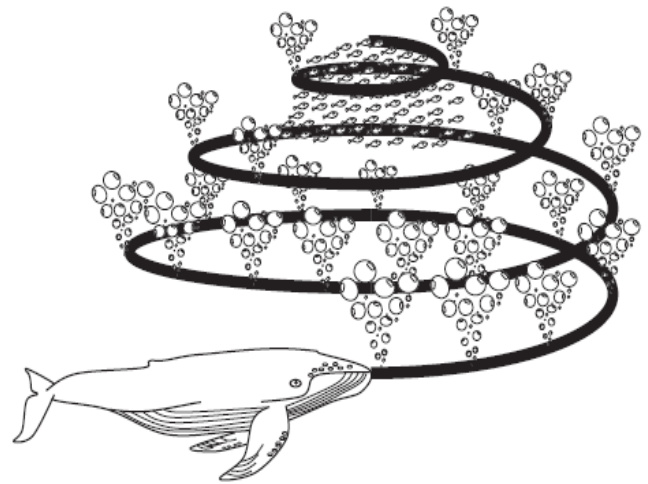

Fig. 3 Bubble-net feed hunting behavior of humpback whales

Humpback whales encircles the prey during hunt and encircling behavior can be mathematically modeled as

$$\vec{D} = |\vec{C} \cdot \vec{X}^*(k) - \vec{X}(k)| \quad (10)$$

$$\vec{X}(k+1) = \vec{X}^*(k) - \vec{A} \cdot \vec{D} \quad (11)$$

where D , A and C are the coefficient vectors, k is the current iteration, X^* is the best solution and it updates for each iteration if better solution obtained, X is the position vector of the whales. The A and C vectors can be calculated as

$$\vec{A} = 2\vec{a} \cdot \vec{r} - \vec{a} \quad (12)$$

$$\vec{C} = 2\vec{r} \quad (13)$$

where a linearly decreases from 2 to 0 over course of iterations and r is the random vector between $[0,1]$. Here we refer X^* as the best solution with knowledge about the prey location.

3.2 Application of WOA for MPPT

Here MPPT is formulated as objective function and it is represented as follows:

$$\text{Maximize } P(d) \quad (14)$$

$$\text{Subjected to } d_{\min} \leq d \leq d_{\max} \quad (15)$$

where P is PV output power, d is duty ratio, d_{\min} is the minimum and d_{\max} is the maximum limits of duty ratio i.e., 0.1 and 0.9, respectively. The block diagram for MPPT of PV system is depicted in Fig. 4.

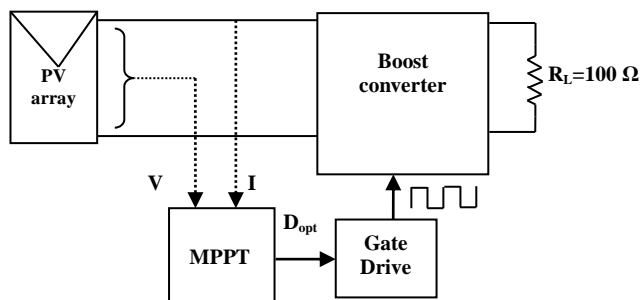

Fig. 4 Block diagram for MPPT of PV system

In this work WOA is implemented as a direct control MPPT technique i.e., duty cycle control by taking population of whales as duty ratios to reduce steady state oscillations. Direct control MPPT decreases power loss and therefore improves efficiency of the system. For each population of whales, i.e., duty ratios, the corresponding voltage and currents are sensed by the controller and compute output power.

For MPPT, (11) can be remodeled as

$$d_i(k+1) = d_i(k) - A.D \quad (16)$$

The objective function of WOA MPPT is formulated as

$$P(d_i^k) > P(d_i^{k-1}) \quad (17)$$

where i is the population of whales

PV power is dependent on climatic conditions, for a change in solar irradiation of PV modules, the power output of PV array changes correspondingly and proposed MPPT algorithm is reinitialized by sensing the change in PV output power using (18).

$$\frac{P^k - P^{k-1}}{P^k} \geq 0.1 \quad (18)$$

The detailed methodology of proposed WOA MPPT algorithm is presented in Fig. 5.

4. Results and discussions

To examine the performance of proposed WOA MPPT algorithm, it is implemented for different combinations of PV configurations of six PV modules.

The shading patterns (W/m^2) of 6S PV configuration are as follows:

- 1) $G_1, G_2=1000, G_3, G_4=600, G_5, G_6=200$
- 2) $G_1=1000, G_2=800, G_3=600, G_4=400, G_5=200, G_6=100$

The shading patterns of 3S2P PV configuration are as follows:

- 3) $G_1=1000, G_2=500, G_3=200, G_4=1000, G_5=600, G_6=200$
- 4) $G_1=1000, G_2=400, G_3=200, G_4=1000, G_5=500, G_6=300$

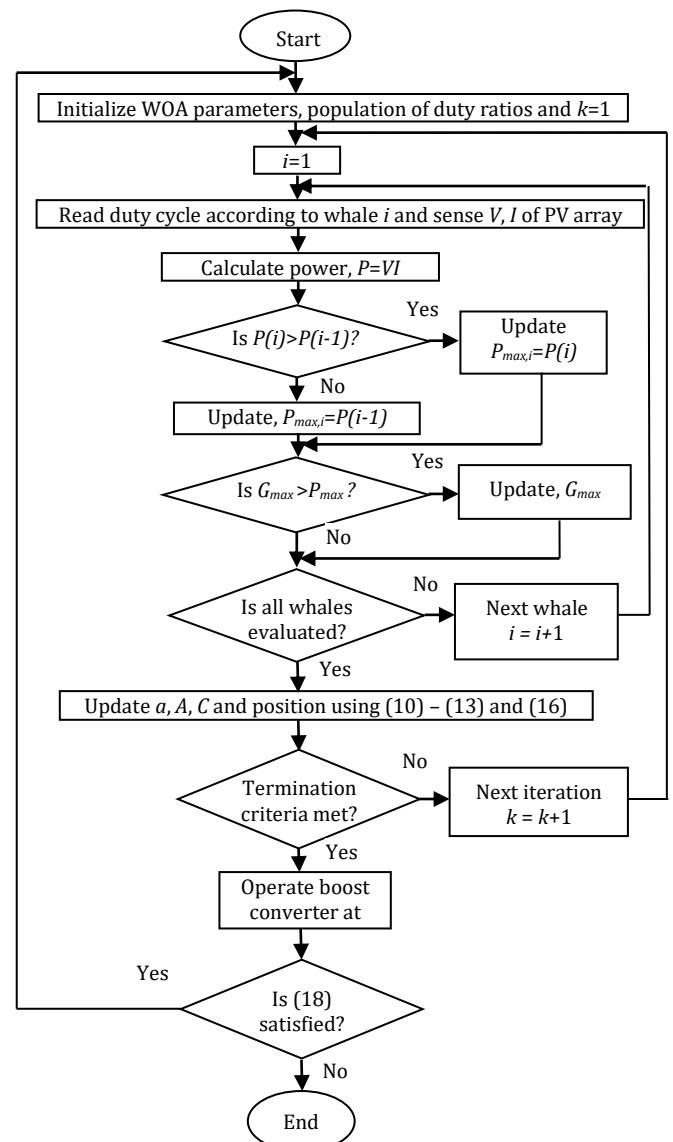

Fig. 5 Flow chart for WOA MPPT Algorithm

The shading patterns of 2S3P PV configuration are as follows:

- 5) $G_1=1000, G_2=600, G_3=1000, G_4=600, G_5=1000, G_6=600$
- 6) $G_1=1000, G_2=300, G_3=1000, G_4=200, G_5=1000, G_6=100$

4.1 PV configuration 6S

The P-V characteristics of 6S PV configuration for shading patterns 1 and 2 are shown in Fig. 6. These characteristics exhibit multiple maxima due to bypass diode operation across shaded modules, out of which only one is GMPP. In order to attain maximum benefit, the PV system should be operated at GMPP. This can be achieved by using the proposed MPPT technique.

The dynamic performance of the proposed algorithm is observed by operating the PV system at different shading patterns. The 6S PV configuration is subjected to pattern 1 from 0 to 30s and pattern 2 from 30s onwards. The algorithm reinitializes the search for change in shading pattern by sensing the change in the PV power. The tracking curves of proposed WOA MPPT algorithm for shading patterns 1 and 2 of 6S PV configuration are presented in Fig. 7.

From Fig. 7, it is clear that MPP tracking subjected to shading pattern 1 and 2 can be achieved by proposed MPPT algorithm. The maximum power extracted by proposed algorithm for pattern 1 is 394.52 W and the time for tracking the MPP is 5.4 s and at $t=30$ s algorithm reinitializes the search due to change in PV power, for pattern 2 the maximum power is 301.9 W and the time of tracking the MPP is 5.5 s. For comparative analysis, the proposed algorithm is compared with most recent GWO MPPT algorithm (Satyajit *et al.* 2016), and most implemented PSO MPPT algorithm (Ishaque *et al.* 2012) under similar conditions. The parameters of the three algorithms are given in Appendix. For fairness of comparison same number of population i is considered for all the algorithms.

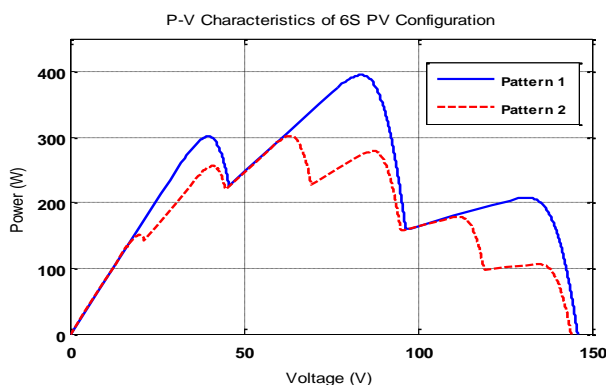

Fig. 6 P-V Characteristics of 6S PV configuration

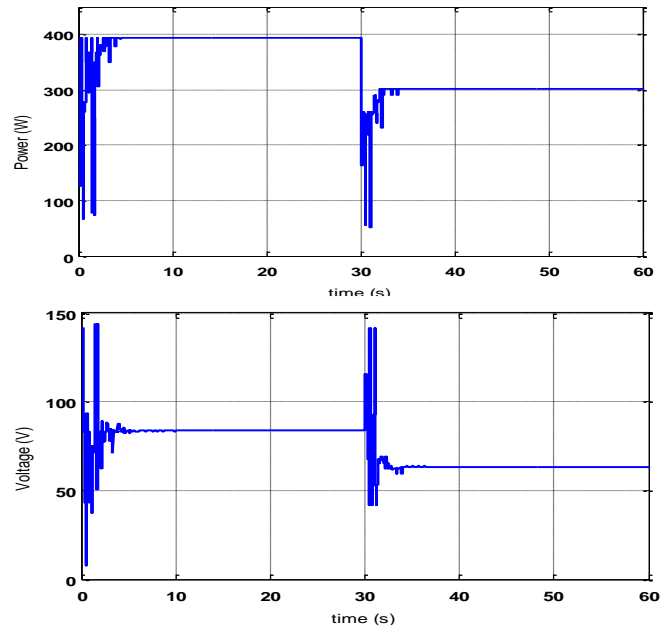

Fig. 7 Tracking Curves of Power and Voltage of 6S PV Configuration

4.2 PV configuration 3S2P

The P-V characteristics of 3S2P PV configuration for shading patterns 3 and 4 are shown in Fig. 8.

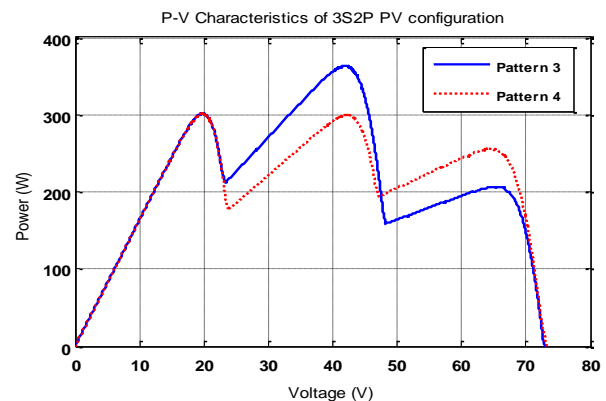

Fig. 8 P-V Characteristics of 3S2P PV configuration

The 3S2P PV configuration is subjected to pattern 3 from 0 to 30s and pattern 4 from 30s onwards. The proposed algorithm tracks the global MPP for both shading patterns. The tracking curves of proposed MPPT algorithm for shading patterns 3 and 4 of 3S2P PV configuration are presented in Fig. 9.

From Fig. 9 it is clear that MPP tracking subjected to shading pattern 3 and 4 can be achieved by proposed MPPT algorithm. The maximum power extracted by proposed algorithm for pattern 3 is 363.09 W and the time of tracking the MPP is 4.9 s and for pattern 4 is 301.05 W and the time of tracking the MPP is 4.6 s.

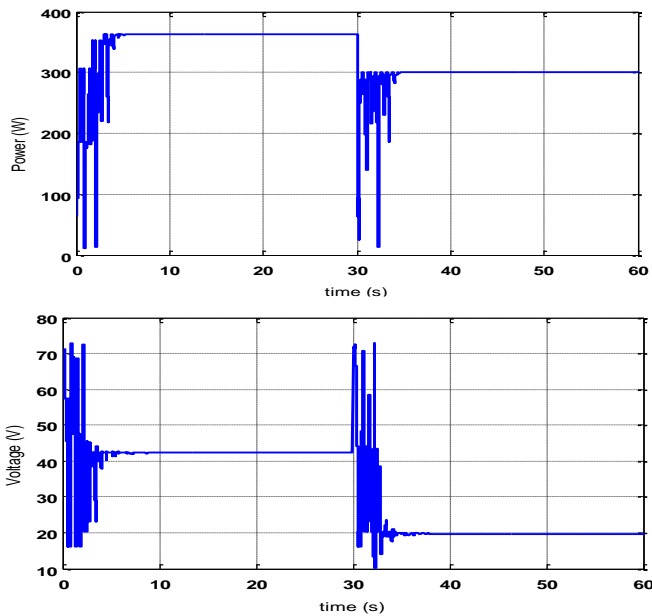

Fig. 9 Tracking Curves of Power and Voltage of 3S2P PV Configuration

4.3 PV configuration 2S3P

The P-V characteristics of 2S3P PV configuration for shading patterns 5 and 6 exhibits two maxima, out of which only one is GMPP are shown in Fig. 10.

The 2S3P PV configuration is subjected to pattern 5 from 0 to 30s and pattern 6 from 30s. The tracking curves of proposed MPPT algorithm for shading patterns 5 and 6 of 2S3P PV configuration are presented in Fig. 11.

From Fig. 11 it is clear that MPP tracking subjected to shading pattern 5 and 6 can be achieved by proposed MPPT algorithm. The maximum power extracted by proposed algorithm for pattern 5 is 592.08 W and the time of tracking the MPP is 6.6 s and for pattern 6 is 451.57 W and the time of tracking the MPP is 6.2 s.

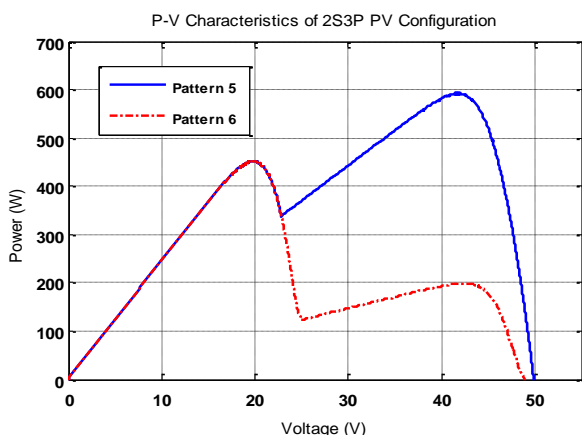

Fig. 10 P-V Characteristics of 2S3P PV configuration

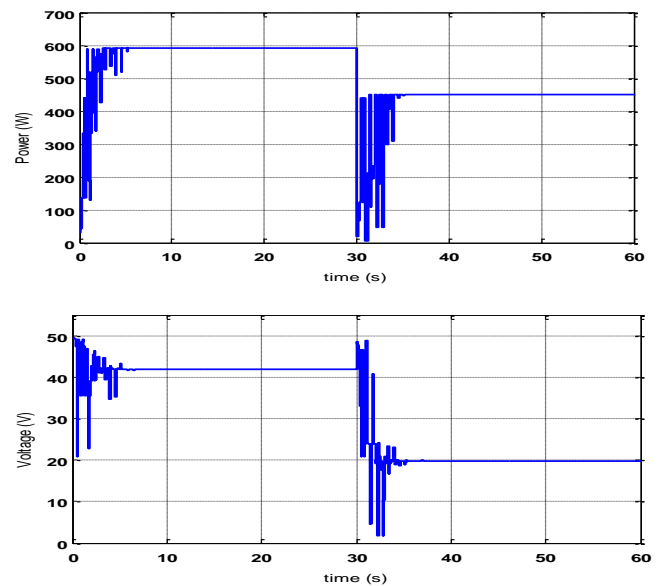

Fig. 11 Tracking Curves of Power and Voltage of 3S2P PV Configuration

4.4 Performance comparison

To compare the performance of proposed WOA MPPT, GWO and PSO MPPT algorithms in terms of tracking speed and tracking efficiency subjected to all shading patterns of 6S, 3S2P and 2S3P PV configurations, results are presented in Table 2. For any MPPT algorithm both tracking efficiency and tracking time are very important to attain highest benefit from the PV system. Tracking efficiency is the ratio between maximum power tracked by algorithm to maximum power of the PV configuration (Liu *et al.* 2012). From Table 2, it is observed that proposed algorithm has superior tracking efficiency and tracking speed than GWO and PSO MPPT algorithms.

The performance comparison between three algorithms in terms of global maximum power extraction and tracking speeds are shown in Fig. 12 and Fig. 13.

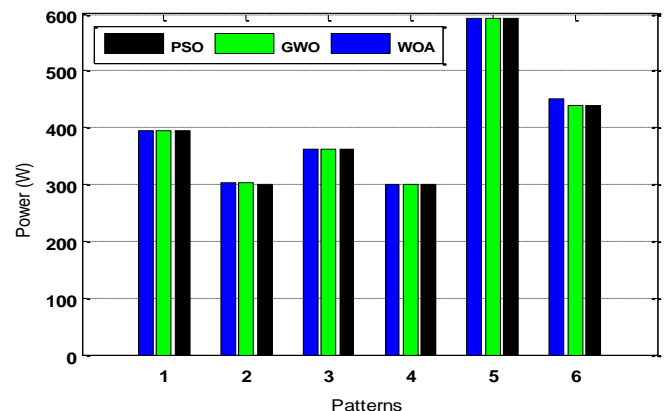
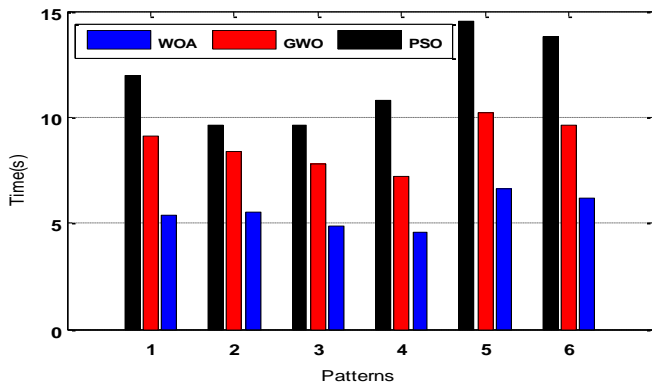

Fig.12 Maximum power extracted by MPPT methods



Due to stochastic nature of the optimization algorithms, 50 trail runs were performed with the proposed and other algorithms and the statistical results are given in Table 3. From Table 3 it is noticed that the proposed algorithm has very low standard deviation compared to GWO and PSO MPPT algorithms, where as PSO MPPT suffers from LMPP trapping and leads to wastage of viable PV power.

Fig.13 Tracking speeds of MPPT methods

Table 1 Performance Comparison of WOA, GWO and PSO MPPT Methods

PV configuration	Shading pattern	Tracking method	PV power (W)	PV voltage (V)	PV current (A)	Duty ratio (d _{optimum})	Tracking time (s)	Maximum power from P-V curve (W)	Tracking efficiency (%)
6S	1	WOA	394.52	83.58	4.72	0.5792	5.4	394.52	99.99
		GWO	394.52	84.07	4.69	0.5788	9.1		99.99
		PSO	394.52	84.64	4.66	0.5793	12		99.99
3S2P	2	WOA	301.9	63.31	4.76	0.6357	5.5	301.99	99.97
		GWO	301.9	63.31	4.76	0.6357	8.4		99.97
		PSO	300.8	68.09	4.41	0.6356	9.6		99.60
3S2P	3	WOA	363.09	42.22	8.59	0.7789	4.9	363.27	99.95
		GWO	363.01	42.22	8.59	0.7801	7.8		99.92
		PSO	363.05	44.26	8.20	0.7801	9.6		99.93
2S3P	4	WOA	301.05	19.78	15.21	0.7759	4.6	301.05	99.99
		GWO	300.95	21.30	14.12	0.8859	7.2		99.93
		PSO	299.41	24.52	12.21	0.7559	10.8		99.45
2S3P	5	WOA	592.08	41.83	14.15	0.8281	6.6	592.31	99.96
		GWO	591.19	41.66	14.19	0.8280	10.2		99.81
		PSO	591.90	41.36	14.31	0.8281	14.5		99.93
2S3P	6	WOA	451.57	19.78	22.82	0.9069	6.2	451.57	99.99
		GWO	438.69	20.95	20.93	0.9001	9.6		97.14
		PSO	438.69	20.95	20.93	0.8999	13.8		97.14

Table 2 Statistical Comparison of WOA, GWO and PSO MPPT Methods

PV configuration	Shading pattern	Tracking method	Mean best values (W)	Standard deviation (W)	Maximum power value (W)	Minimum power value (W)	Average tracking time(s)
6S	1	WOA	394.5273	0.0000	394.5273	394.5273	5.4
		GWO	394.5273	0.0000	394.5273	394.5273	9.1
		PSO	394.5262	0.0045	394.5273	394.5087	12
3S2P	2	WOA	301.9921	0.0000	301.9921	301.9921	5.5
		GWO	301.9920	0.0000	301.9921	301.9854	8.4
		PSO	301.9919	0.0013	301.9921	301.9854	9.6
3S2P	3	WOA	363.2528	0.0372	363.2730	363.1380	4.9
		GWO	363.1832	0.0894	363.2730	362.8944	7.8
		PSO	350.7179	42.8	363.2730	207.0327	9.6
2S3P	4	WOA	300.9113	0.4523	301.0516	299.3440	4.6
		GWO	300.9214	0.2451	301.0516	299.3004	7.2
		PSO	293.8197	15.3695	301.0516	256.1528	10.8
2S3P	5	WOA	592.3051	0.0362	592.3128	592.0590	6.6
		GWO	592.2184	0.1492	592.3128	299.3004	10.2
		PSO	592.2854	0.0617	592.3128	256.1528	14.5
2S3P	6	WOA	438.7851	0.1050	438.9024	438.6930	6.2
		GWO	438.7349	0.0846	438.9024	438.6930	9.6
		PSO	352.4406	116.2678	438.9024	198.9040	13.8

5. Conclusion

In this paper a novel WOA MPPT algorithm is proposed to track GMPP of PV system subjected to Partial shading condition. The P-V characteristics of 6S, 3S2P and 2S3P configurations considering both series and shunt resistances under different partial shading conditions are presented. These characteristics exhibit multiple MPPs of which one is the GMPP and all other are LMPP. It is observed that the characteristics are highly non-linear and it is complex to track GMPP under Partial shaded condition. The proposed WOA algorithm is used to track the GMPP for above configurations and it is effective in tracking the GMPP with high accuracy and less tracking time under dynamic partial shading conditions. From results, it is seen that proposed method is superior in terms of accuracy and tracking time compared to GWO and PSO MPPT algorithms. Since the algorithms WOA, GWO and PSO are stochastic in nature, the simulations are carried for 50 trials and statistical results are presented. It is observed that the Standard Deviation (SD) of the proposed is less compared to other methods which show that the WOA is able track the GMPP effectively. But SD of PSO is very high because maximum value is trapped at local value. From results and statistical analysis, it is seen that proposed WOA MPPT algorithm proved its supremacy over GWO and PSO MPPTs.

Appendix

Parameters of PSO, GWO and WOA MPPT Algorithms

Parameter	PSO	GWO	WOA
Initial population (duty ratio)	Randomly between 0.1 and 0.9	Randomly between 0.1 and 0.9	Randomly between 0.1 and 0.9
N_p	6	6	6
$C_{1,max}$	2	-	-
$C_{2,max}$	2	-	-
$C_{1,min}$	1	-	-
$C_{2,min}$	1	-	-
W_{max}	1	-	-
W_{min}	0.1	-	-
Maximum number of iterations, k_{max}	100	100	100
Termination criteria	k_{max}	k_{max}	k_{max}

References

- Ahmed, J. & Salam, Z. (2014) A maximum power point tracking (MPPT) for PV system using Cuckoo search with Partial shading capability. *Appl Energy*, 119, 118-130.
- Ahmed, J. & Salam, Z. (2015) A critical evaluation on maximum power point tracking methods for partial shading in PV systems, *Renewable & Sustainable Energy Rev*, 47, 933-953.
- Bader, N.A., Khaled. H.A., Stephen, J.F. & Barry. W.W. (2013) A Maximum power point tracking technique for partially shaded photovoltaic systems in microgrids, *IEEE Trans.Ind.Electro*, 60(4), 1596-1606.
- Benyoucef, A.S., Chouder, A., Kara, K., Silvestre, S. & Sahed, O.A. (2015) Artificial bee colony based algorithm for maximum power point tracking (MPPT) for PV systems operating under partial shaded conditions. *Applied Soft Computing*, 32, 38-48.
- Daraban, S., Petreus, D. & Morel, C. (2014) A novel MPPT algorithm based on a modified genetic algorithm specialized on tracking the global maximum power point in photovoltaic systems affected by partial shading. *Energy*, 74, 374-388.
- Ishaque, K. & Salam, Z. (2013) A review of maximum power point tracking techniques of PV system for uniform isolation and partial shading condition. *Renewable & Sustainable Energy Rev*, 19, 475-488.
- Ishaque, K., Salam, Z., Amjad, M. & Mekhilef, S. (2012) An improved particle swarm optimization (PSO)-based MPPT for PV with reduced steady state oscillations. *IEEE Trans Power Electron*, 27(8), 3627-3637.
- Ishaque, K., Salam, Z., Shamsudin, A. & Amjad, M. (2012) A direct control based maximum power point tracking method for photovoltaic system under partial shading conditions using particle swarm optimization algorithm. *Applied Energy*, 99, 414-422.
- Jiang, L.L., Maskell, D.L. & Patra, J.C. (2013) A novel ant colony optimization based maximum power point tracking for photovoltaic systems under partially shaded condition. *Energy & Buildings*, 58, 227-236.
- Kamarzaman, N.A. & Tan, C.W. (2014) A comprehensive review of maximum power point tracking algorithms for photovoltaic systems. *Renewable & Sustainable Energy Rev*, 32, 585-598.
- Liu, Y.H., Chen, J.H. & Huang, J.W. (2015) A review of maximum power point tracking techniques for use in partially shaded condition. *Renewable & Sustainable Energy Rev*, 41, 436-453.
- Liu, Y.H., Huang, S.C., Huang, J.W. & Liang, W.C. (2012), "A particle swarm optimization based maximum power point tracking algorithm for PV systems operating under partially shaded conditions. *IEEE Trans Energy Conv*, 27(4), 1027-1035.
- Mirjalili, S. & Lewis, A. (2016) The whale optimization algorithm, *Advances in Engg Software*, 95, 51-67.
- Reisi, A.R., Moradi, M.H. & Jamasb, S. (2013) Classification and comparison of maximum power point tracking techniques for photovoltaic system: A review. *Renewable & Sustainable Energy Rev*, 19, 433-443, 2013.
- Satyajit, Mohanty., Bidyadhar, Subudhi. & Pravat, Kumar.Ray. (2016) A new MPPT design using grey wolf optimizer technique for photovoltaic system under partial shading conditions. *IEEE Trans on sustainable energy*, 7(1), 181-188.
- Silvestre, S., Boronat, A. & Chouder, A. (2009) Study of bypass diodes configuration on PV modules. *Applied Energy*, 86, 1632-1640.
- Sundareswaran, K., Sankar, P. & Sankaran, P. (2014) MPPT of PV systems under partial shaded Conditions through a colony of flashing fireflies. *IEEE Trans Ener Conv*, 29(2), 463-472.
- Sundareswaran, K., Sankar, P., Nayak, P.S.R., Simon, S.P. & Palani, S.(2015) Enhanced energy output from a PV system under partial shaded conditions through Artificial bee colony. *IEEE Trans Sustainable Ener*, 6(1), 198-209.
- T, Ma., H, Yang. & L, Lu. (2014) Solar photovoltaic system modeling and performance prediction, *Renewable & Sustainable Energy Rev*, 36, 304-315.
- Tajuddin, M.F.N., Ayob, S.M, Sala, Z. & Saad, M.S. (2013) Evolutionary based maximum power point tracking technique using differential evolution algorithm. *Energy & Buildings*, 67, 245-252.
- Zainal, Salam., Jubaer, Ahmed. & Beny, S.Merugu. (2013) The application of soft computing methods for MPPT of PV system: A technological and status review. *Applied Energy*, 107, 135-148.