

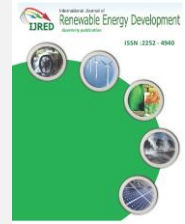

Contents list available at IJRED website

Int. Journal of Renewable Energy Development (IJRED)

Journal homepage: <http://ejournal.undip.ac.id/index.php/ijred>



Enhanced Grey Wolf Optimizer Based MPPT Algorithm of PV System Under Partial Shaded Condition

Ch. Santhan Kumar^{a*} and R. Srinivasa Rao^a

^aDepartment of Electrical and Electronics Engineering, JNT University Kakinada, Kakinada, Andhra Pradesh 533003, India

ABSTRACT: Partial shading condition is one of the adverse phenomena which effects the power output of photovoltaic (PV) systems due to inaccurate tracking of global maximum power point. Conventional Maximum Power Point Tracking (MPPT) techniques like Perturb and Observe, Incremental Conductance and Hill Climbing can track the maximum power point effectively under uniform shaded condition, but fails under partial shaded condition. An attractive solution under partial shaded condition is application of meta-heuristic algorithms to operate at global maximum power point. Hence in this paper, an Enhanced Grey Wolf Optimizer (EGWO) based maximum power point tracking algorithm is proposed to track the global maximum power point of PV system under partial shading condition. A Mathematical model of PV system is developed under partial shaded condition using single diode model and EGWO is applied to track global maximum power point. The proposed method was programmed in MATLAB environment and simulations are carried out on 4S and 2S2P PV configurations for dynamically changing shading patterns. The results of the proposed method were analyzed and compared with GWO and PSO algorithms. It was observed that proposed method is effective in tracking global maximum power point with more accuracy in less computation time compared to other methods.

Keywords: Enhanced Grey Wolf Optimizer, Maximum power point tracking, Partial shaded condition, PV system, Single diode model.

Article History: Received June 12nd 2017; Received in revised form August 13rd 2017; Accepted August 15th 2017; Available online

How to Cite This Article: Kumar, C.H.S and Rao, R.S. (2017) Enhanced Grey Wolf Optimizer Based MPPT Algorithm of PV System Under Partial Shaded Condition. Int. Journal of Renewable Energy Development, 6(3), 203-212.

<https://doi.org/10.14710/ijred.6.3.203-212>

1. Introduction

Almost all the countries in the world are adopting solar photovoltaic systems as an alternative to conventional power generation due to several advantages like reduced green house gas emission, inexhaustible nature of solar energy, eco-friendly nature etc. India is also targeting 100 GW of electrical power generation by 2022 through small and large-scale solar parks to meet the growing power demand (JNNSM, 2016).

The PV system is equivalently represented in single or two-diode model and due to its low efficiency, it is necessary to operate it at maximum power point (MPP) in order to attain highest power output. PV systems are subjected to several atmospheric conditions, partial shaded condition (PSC) is one such phenomenon, where PV modules are subjected to partial shading (due to passing clouds, building shadows, bird waste etc.). When PV system is

subjected to PSC its nonlinear characteristics exhibit multiple maximum power points due to bypass diode operation across shaded modules (Silvestre *et al.* 2009), therefore it is necessary to operate at global MPP.

There are many methods available to mitigate the effect of PSC viz. MPPT Controllers, PV Array Reconfiguration, Power electronic converter configurations etc. In this work MPPT controller is used to operate PV system at global MPP under PSC. Though classical MPPT techniques like Perturb and Observe (P&O), Incremental Conductance (INC), Hill Climbing (HC) etc. work efficiently to track MPP under uniform shaded condition, but fails to track global MPP under PSC (Ankit *et al.* 2016, Deepak *et al.* 2016). In literature, some of the authors (Makbul *et al.* 2017, Saravanan *et al.* 2016) applied intelligence based techniques like ANN and Fuzzy systems to extract maximum power under PSC, but these

*Corresponding Author: +919885554065; Fax: 08847772000
Email: wizesk@gmail.com

techniques need proper training and rules formulations, which are system dependent.

In recent times, meta-heuristic based MPPT techniques became popular because of their accuracy and system independency (Zainal *et al.* 2013). Several authors proposed MPPT algorithms based on Particle Swarm Optimization (Ishaque *et al.* 2012 – Liu *et al.* 2012), Artificial Bee Colony (Sundareswaran *et al.* 2015), Ant Colony Optimization (Jiang *et al.* 2013), Cuckoo Search (Ahmed *et al.* 2014), Firefly (Sundareswaran *et al.* 2014), Grey Wolf Optimizer (Satyajit *et al.* 2016) and Whale Optimization Algorithm (Santhan *et al.* 2016). All these algorithms differ noticeably in terms of accuracy, efficiency, tracking time and complexity (Jordehi 2016). In general, MPPT techniques are classified into direct and indirect control techniques based on the decision variable employed in tracking the MPP.

In conventional GWO Algorithm, δ and ω wolves participate in search process, as they are subordinates to α and β , these wolves does not contribute much in hunting the prey (Mirjalili *et al.* 2014).

In this paper, an Enhanced Grey Wolf Optimizer (EGWO) MPPT Algorithm is proposed by eliminating the δ and ω wolves phase, entire herd is considered as α and β wolves, where α is the leader for the herd and gives optimal solution. Hence, the proposed EGWO leads to quick search process to track global MPP in less time.

The rest of the paper is as follows: Section 2 briefly describes modeling of PV system under partial shaded condition; Section 3 gives an overview of conventional GWO and proposed EGWO algorithm and its application for MPPT of PV system; Section 4 presents the results and comparison; and finally conclusions are given in section 5.

2. Characteristics of PV system under PSC

2.1 Photovoltaic module

The Equivalent circuit diagram for Single diode PV cell is shown in Fig. 1.

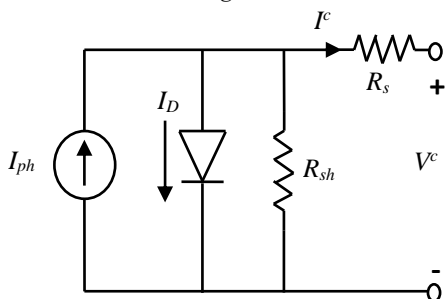

Fig. 1 Single diode model PV cell

Single diode model of PV cell is mostly used in modeling of PV system due to reduced complexity and computational efficiency over two-diode model

(Giuseppina *et al.* 2014, Sangram *et al.* 2016).

The output current of PV cell is written as

$$I^c = I_{PV} - I_0 \left[e^{\left(\frac{q(V^c + I^c R_s)}{KTA} \right)} - 1 \right] - \left(\frac{V^c + I^c R_s}{R_{sh}} \right) \quad (1)$$

where I^c is PV cell output current, V^c is PV cell output voltage, I_{pv} is photo current, I_0 is diode reverse saturation current, R_s and R_{sh} are series and shunt resistances, q is charge of an electron (1.6×10^{-19} C), A is diode ideality factor, K is Boltzmann's constant (1.38×10^{-23} N-m/K), T is panel operating temperature (in Kelvin).

The output current of PV module with N_s number of PV cells is given as

$$I = I_{PV} - I_0 \left[e^{\left(\frac{q(V + IR_s)}{N_s KTA} \right)} - 1 \right] - \left(\frac{V + IR_s}{R_{sh}} \right) \quad (2)$$

$$I_{PV} = (I_{PV_STC} + k_i \Delta T) \frac{G}{G_{STC}} \quad (3)$$

$$I_0 = I_{o_STC} \left(\frac{T_{STC}}{T} \right)^3 e^{\left[\frac{qE_g}{AK} \left(\frac{1}{T_{STC}} - \frac{1}{T} \right) \right]} \quad (4)$$

$$I_{o_STC} = \frac{I_{sc_STC}}{e^{\left(\frac{qV_{oc_STC}}{N_s AKT_{STC}} \right)} - 1} \quad (5)$$

where V is PV voltage, I is PV current, V_t is thermal voltage of PV module, I_{PV_STC} is photo current at standard test conditions (STC), k_i is current temperature coefficient, G is solar irradiation in kW/m², ΔT is temperature change ($\Delta T = T - T_{STC}$) in Kelvin, I_{o_STC} is diode reverse saturation current at STC, E_g is energy band gap (eV), V_{oc_STC} and I_{sc_STC} are open circuit voltage and short circuit current of PV module at STC.

In order to get the module voltage, (2) is modified as

$$V = \frac{N_s KTA}{q} \left[\ln \left(\frac{I_{ph} + I_0 - I \left(1 + \frac{R_s}{R_{sh}} \right)}{I_0} \right) \right] - IR_s \quad (6)$$

2.2 Modeling of Partial shading condition

A PV system is modeled using four PV modules and these are represented in the form of four series (4S) and two series two parallel (2S2P) PV configurations as shown in Fig. 2.

Assume each PV module in Fig. 2(a) receives same irradiation of 1000 W/m² and rating of each module is 200 W at STC. As irradiation is same, bypass diodes

are reverse biased resulting same current flows through all modules and P-V characteristics of array exhibit only single peak MPP.

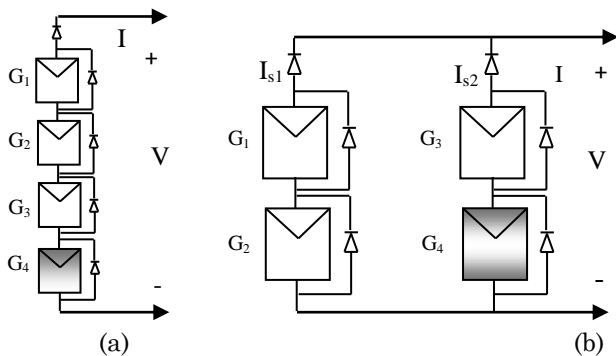

Fig. 2 (a) 4S PV configuration (b) 2S2P PV configuration

When a string is subjected to partial shading, module G_4 receives less irradiation (500 W/m^2) while other modules in the string receives 1000 W/m^2 . The module G_4 acts as load instead of generator and it tries to take the current generated from non-shaded modules. The bypass diode is forward biased and protects the shaded module from being damaged. Due to diversion of current by bypass diode, PV characteristics have multiple peaks of which one is global MPP with reduced output. If bypass diode is removed, array exhibit only one peak but output is drastically reduced. The blocking diodes shown in Fig. 2(b) prevent the reverse current from other strings due to voltage mismatch between two strings.

Output voltage of j^{th} module from (6) is obtained by comparing photo current of j^{th} module with its corresponding string current I_s^i as follows :

$$V^{ij} = \begin{cases} \frac{N_s K T A}{q} \ln \left[\frac{I_{pv}^{ij} + I_o - I_s^i \left(1 + \frac{R_s}{R_{sh}} \right)}{I_o} \right] & I_{pv}^{ij} > I_s^i \\ 0, & I_{pv}^{ij} \leq I_s^i \end{cases} \quad (7)$$

where V^{ij} is voltage across j^{th} module of i^{th} string

By varying current in the string (I_s) from zero to photo current of module with higher irradiation, output voltage of i^{th} string of PV array is given by

$$V_s^i = \sum_{n=1}^m V^{in} \quad (8)$$

where m is number of series connected modules in a string.

Output current of PV array is given by

$$I = \sum_{k=1}^s I_i \quad (9)$$

where s is number of parallel connected strings in an array

3. Enhanced GWO and its application to MPPT

3.1 Overview of Grey Wolf Optimizer

Grey Wolf Optimizer (GWO) is a new meta-heuristic algorithm for non-linear optimization problems from family of swarm intelligence and it is inspired from grey wolves; it mimics the leadership hierarchy and hunting mechanism of grey wolves in nature. In GWO, there are four types of grey wolves such as alpha (α), beta (β), delta (δ) and omega (ω) and they have very strict social dominant hierarchy as shown in Fig. 3, where dominance of wolves decreases from top to bottom. In GWO, α wolves are leaders of the herd and gives fittest solution of optimization problem, β wolves are subordinates to α wolves and they helps in decision making, ω wolves comes under third class and δ wolves dominate ω wolves and they have to submit to α and β (Mirjalili *et al.* 2014).

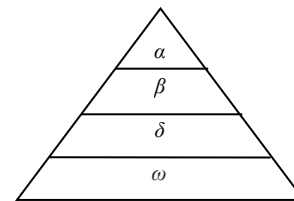

Fig. 3 Hierarchy of grey wolves

There are three main steps in hunting i.e., searching for prey, encircling prey and attacking the prey. The cooperation and communication between wolves gives optimal solution in least time.

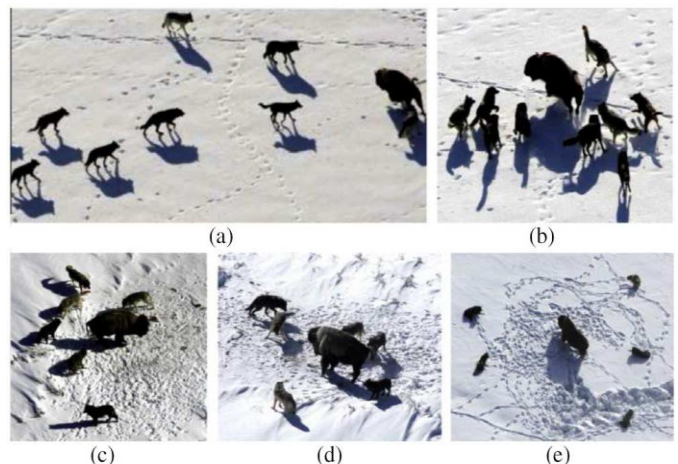

Fig. 4. Hunting behavior of grey wolves: (a-c) chasing, approaching, and tracking prey (d) encircling (e) stationary situation and attack

Hunting behavior of grey wolves is shown in Fig. 4. This algorithm is simple in principle with good convergence speed and high accuracy and it has proper balance between both exploration and exploitation phases of search process (Mirjalili *et al.* 2014).

3.2 Enhanced Grey Wolf Optimizer

In conventional GWO, δ and ω wolves submit to α and β wolves and do not contribute much in hunting the prey. This leads to higher population of search agents and wastage of time for tracking the optimal solution. In the proposed Enhanced GWO algorithm δ and ω phase is completely eliminated to speed up search process without compromising the accuracy of optimal solution. The modified steps to determine encircling and hunting behavior of proposed EGWO algorithm are as follows (Mirjalili *et al.* 2014):

- **Encircling**

Each search agent encircles the prey during hunt. The encircling behaviour is mathematically modeled as

$$\vec{D} = |\vec{C} \cdot \vec{X}_p(t) - \vec{X}_{sg}(t)| \quad (10)$$

$$\vec{X}_{sg}(t+1) = \vec{X}_p(t) - \vec{A} \cdot \vec{D} \quad (11)$$

where t is current iteration and

$$\vec{A} = 2a \cdot \vec{r}_1 - a \quad (12)$$

$$\vec{C} = 2 \cdot \vec{r}_2 \quad (13)$$

where A , C are coefficients to maintain proper balance between exploration and exploitation, r_1 and r_2 are random numbers between $[0, 1]$ and a is linearly decreased from 2 to 0 over course of iterations that resembles approaching the prey.

- **Hunting**

The positions of all search agents are updated according to positions of best search agents X_α and X_β , for each iteration using following equations

$$\vec{D}_\alpha = |\vec{C}_1 \cdot \vec{X}_\alpha - \vec{X}_{sg}|, \quad \vec{D}_\beta = |\vec{C}_2 \cdot \vec{X}_\beta - \vec{X}_{sg}| \quad (14)$$

$$\vec{X}_1 = \vec{X}_\alpha - \vec{A}_1 \cdot (\vec{D}_\alpha), \quad \vec{X}_2 = \vec{X}_\beta - \vec{A}_2 \cdot (\vec{D}_\beta) \quad (15)$$

$$\vec{X}_{sg}(t+1) = \frac{\vec{X}_1 + \vec{X}_2}{2} \quad (16)$$

Search agents finish hunt by attacking the prey when it stops moving. The position updating of grey wolves is shown in Fig. 5.

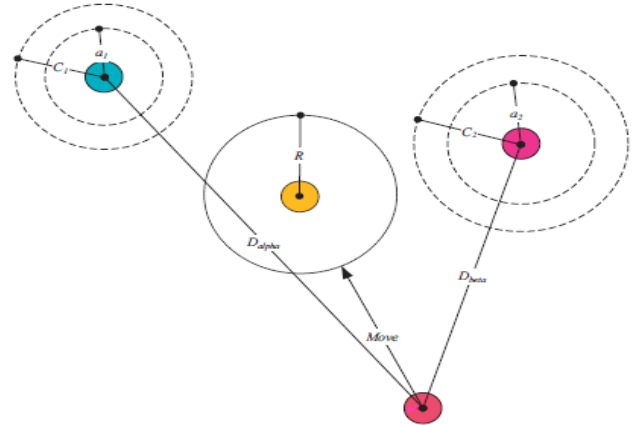

Fig. 5 Position updating of grey wolves

3.3 Application of EGWO for MPPT

The main objective is to obtain the maximized output power P from the PV array considering duty ratio d as the decision variable. The objective function is formulated as follows (Santhan *et al.* 2016):

$$\text{Maximize: } P(d) \quad (17)$$

$$\text{Subjected: } d_{\min} \leq d \leq d_{\max} \quad (18)$$

where d_{\min} and d_{\max} are limits of duty ratio.

The block diagram for MPPT is shown in Fig. 6 and the sequential steps to obtain global MPP using proposed EGWO MPPT algorithm are as follows:

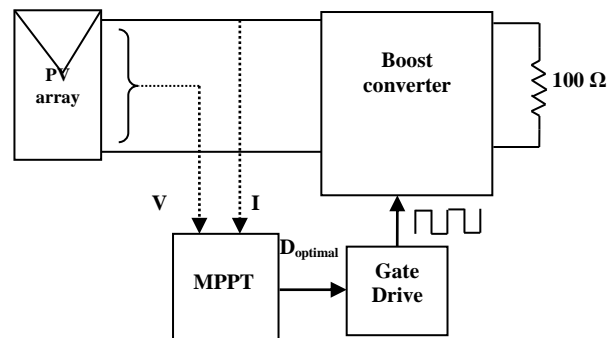

Fig. 6 Block diagram for MPPT Controller

- **Initialization**

Initialize population N_p (wolves) in search space $0.1 \leq d_i \leq 0.9$ between minimum limit, 0.1 and maximum limit, 0.9 of duty ratio using (19):

$$d_i = \text{rand}(N_p, 1)(d_{\max} - d_{\min}) + d_{\min} \quad (19)$$

In this case, N_p is taken as four i.e., number of modules in the PV system.

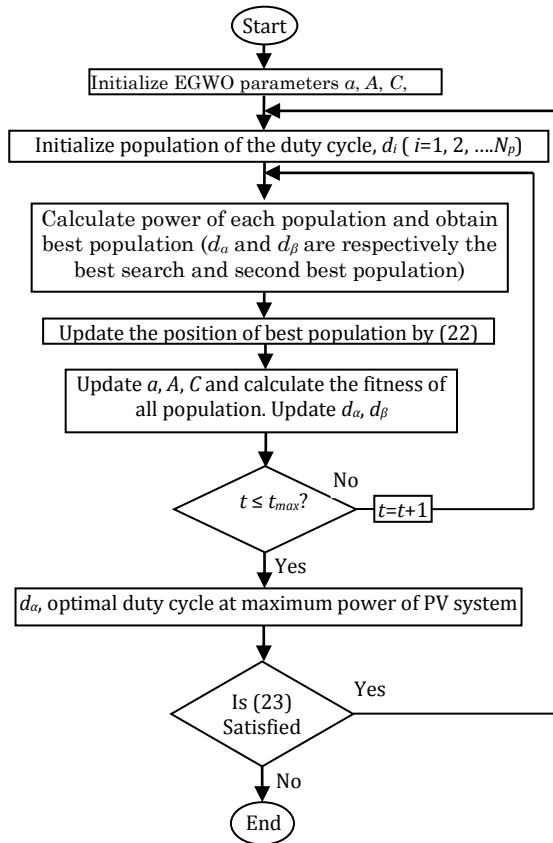

Fig. 7 Flow chart for EGWO MPPT Algorithm

- Evaluate the position of the prey*

Calculate fitness values i.e., PV power of the population. Assign d_α and d_β as first and second best population with highest PV power.
- Updating the positions of search agents*

The positions of the population d_i are updated according to positions of d_α and d_β .

$$\bar{D}_\alpha = |\bar{C}_1 \cdot \bar{d}_\alpha - \bar{d}_i|, \bar{D}_\beta = |\bar{C}_2 \cdot \bar{d}_\beta - \bar{d}_i| \quad (20)$$

$$\bar{d}_1 = \bar{d}_\alpha \cdot \bar{A}_1 \cdot (\bar{D}_\alpha), \bar{d}_2 = \bar{d}_\beta \cdot \bar{A}_2 \cdot (\bar{D}_\beta) \quad (21)$$

$$\bar{d}_{i(t+1)} = \frac{\bar{d}_1 + \bar{d}_2}{2} \quad (22)$$

where D_α and D_β are distance of d_α and d_β from maximum power.

The PV powers are calculated for updated positions of population and finish hunt when prey stops moving i.e., when maximum PV power is obtained.

- Termination criterion*

The algorithm terminates when it reaches maximum number of iterations and outputs d_α as the optimal duty ratio to operate at maximum power.

- Reinitialize*

The algorithm reinitializes search for a change in solar irradiation using

$$\frac{|P_{pv} - P_{pv,old}|}{P_{pv,old}} \geq \Delta P \quad (23)$$

where $P_{pv,old}$ is power at GMPP of last operating point, ΔP is set to 10%.

The flowchart for tracking global MPP using EGWO MPPT algorithm is given in Fig. 7.

4. Results and Comparison

To examine the performance of proposed EGWO MPPT algorithm, simulations were carried on different combinations of four PV modules i.e., four series (4S) and two series two parallel (2S2P) PV configurations subjected to three different shading patterns. The parameters of Kyocera KC 200GT PV module used in modeling the PV system are given in Appendix.

Three shading patterns of 4S PV configuration are as follows:

- 1) $G_1, G_2=1000, G_3, G_4=600$
- 2) $G_1, G_2=1000, G_3, G_4=400$
- 3) $G_1=1000, G_2=600, G_3=400, G_4=200$

Three shading patterns of 2S2P PV configuration are as follows:

- 4) $G_1=1000, G_2=600, G_3=1000, G_4=600$
- 5) $G_1=1000, G_2=400, G_3=1000, G_4=400$
- 6) $G_1=1000, G_2=600, G_3=1000, G_4=400$

4.1 4S PV configuration

The electrical characteristics of the 4S PV configuration subjected shading patterns 1, 2 and 3 are shown in Fig. 8. From figure, it is noticed that characteristics exhibit multiple peaks due to bypass diode operation across the shaded modules subjected to three different shading patterns with many local and one global MPP. The 4S PV configuration is subjected to two and four different irradiances for patterns 1, 2 and 3. The PV system must be operated at global MPP to use maximum available power.

The dynamic performance of proposed algorithm is examined by operating 4S PV configuration at different shading patterns. The 4S PV configuration is subjected to shading pattern 1 from 0-30 sec, pattern 2 from 30-60 sec and pattern 3 from 60 sec. The tracking curves of power, voltage and current of PV array for proposed EGWO algorithms of 4S PV

configuration subjected to three dynamic shading patterns are shown in Fig. 9. From figure, it is noticed that proposed algorithm can efficiently track global MPP for all dynamically changing shading patterns. The algorithm reinitializes search by sensing change in PV power for a change in shading pattern at $t=30$ sec and $t=60$ sec respectively.

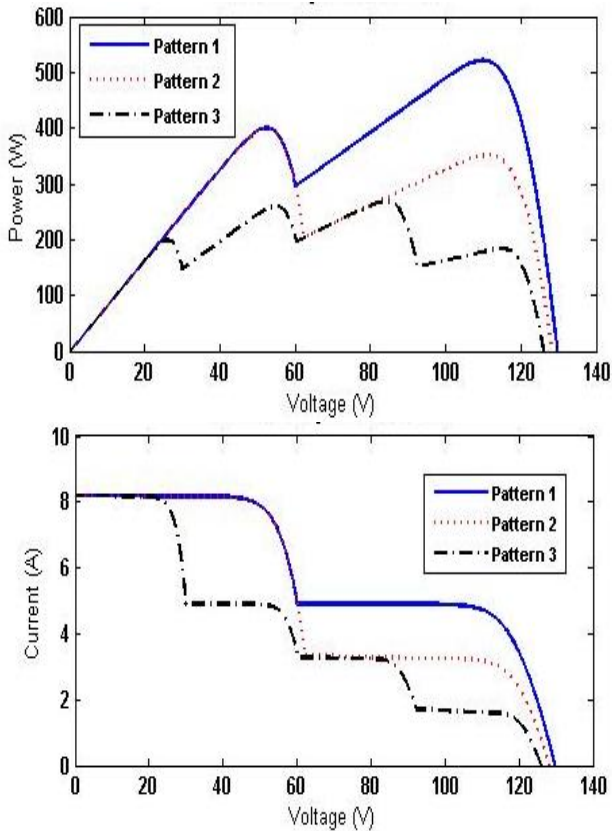

Fig. 8 Electrical characteristics of 4S PV configuration for shading pattern 1, 2 and 3

The maximum power tracked by proposed algorithm for shading pattern 1 is 522.633 W with a tracking time of 3.6 sec, similarly maximum power tracked for shading pattern 2 and 3 are 401.064 W and 270.090 W with a tracking time of 4.8 sec and 5.9 sec respectively.

4.2. 2S2P PV configuration

The electrical characteristics of 2S2P PV configuration subjected to shading patterns 4, 5 and 6 are shown in Fig. 10. From figure, it is noticed that characteristics exhibit two peaks with one global maximum and other is local maxima for shading patterns 4, 5 and 6. The 2S2P PV configuration is subjected to shading pattern 4 from 0-30 sec, pattern 5 from 30-60 sec and pattern 6 from 60 sec respectively to examine dynamic performance of proposed algorithm.

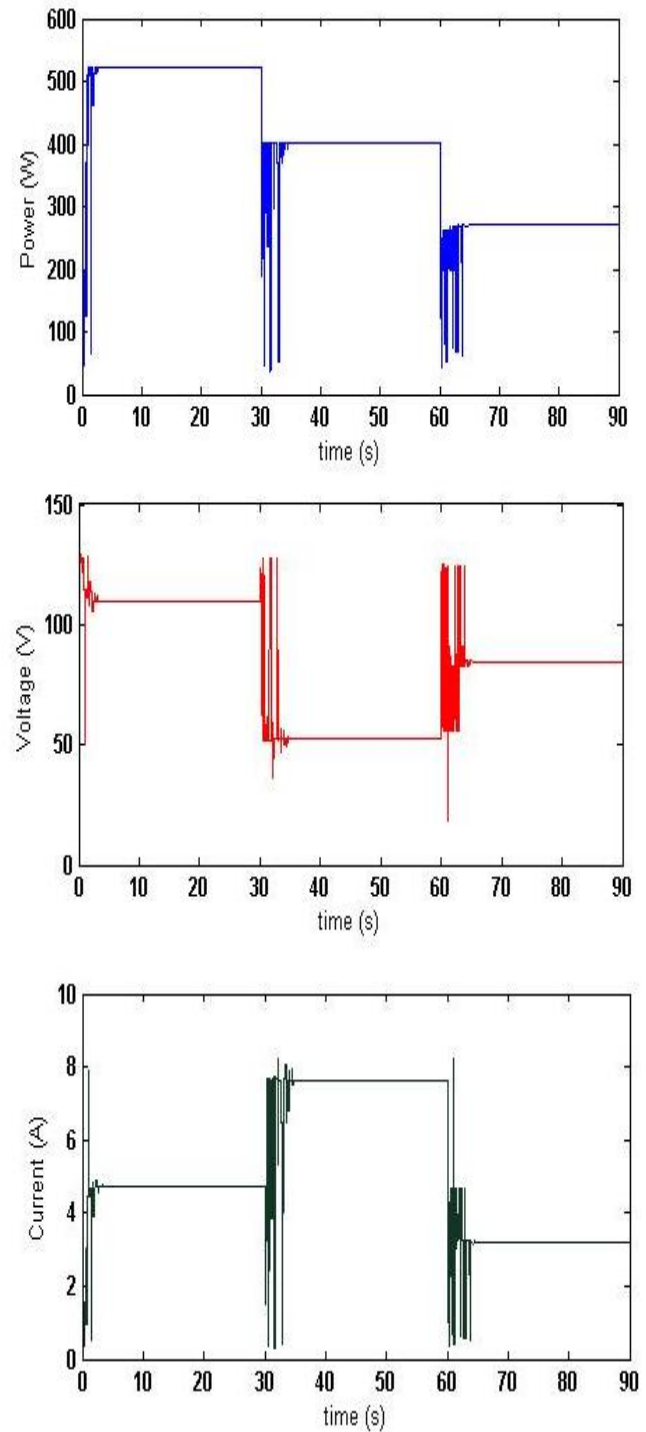

Fig. 9 Tracking curves of 4S PV configuration

The tracking curves of power, voltage and current using proposed algorithm for 2S2P PV configuration subjected to three dynamic shading patterns are shown in Fig. 11. From figure, it is noticed that proposed algorithm tracks global MPP for all shading patterns of 2S2P PV configuration.

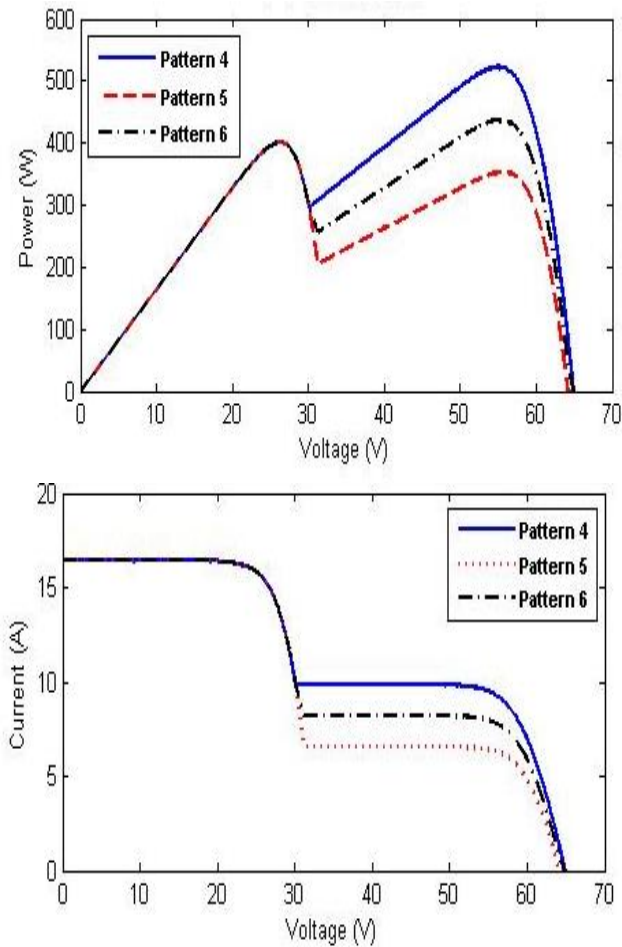

Fig. 10 Electrical characteristics of 2S2P PV configuration for shading pattern 4, 5 and 6

The algorithm reinitializes search at $t=30$ sec and $t=60$ sec for a change in shading pattern. The maximum power tracking by proposed algorithm for shading pattern 4 is 523.078 W in tracking time of 4.5 sec and maximum power of 401.185 W and 437.95 W with a tracking time of 3.5 and 3.7 sec respectively for shading pattern 5 and 6.

4.3 Comparative Analysis

The proposed EGWO algorithm is compared with conventional GWO MPPT algorithm (Satyajit *et al.* 2016) and most implemented Particle Swarm Optimization MPPT algorithms (Liu *et al.* 2012) under similar conditions. The parameters of three algorithms are mentioned in Appendix.

The comparative results for EGWO, GWO and PSO MPPT algorithms in terms of accuracy and speed for tracking of global MPP for all shading patterns of 4S and 2S2P PV configuration are presented in Table 1. From table, it is observed that proposed algorithm is superior to conventional GWO and PSO algorithms.

The statistical performance analysis of EGWO, GWO and PSO MPPT algorithms by performing 50 trail runs are given in Table 2.

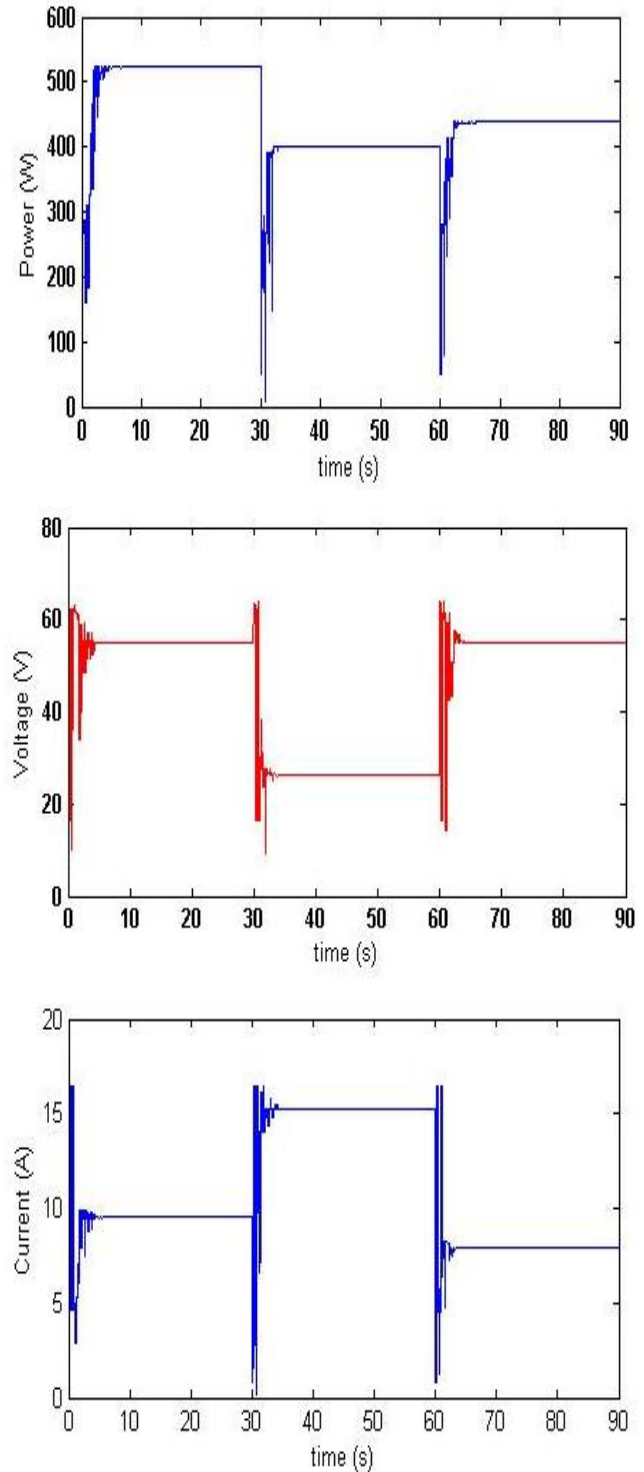

Fig. 11 Tracking curves of 2S2P PV configuration

From Table 2, it is observed that proposed algorithm can track global MPP with more accuracy over PSO algorithm and in less tracking time than GWO MPPT algorithm. The tracking results for 50 trail runs performed by three algorithms for pattern 2 of 4S and pattern 5 of 2S2P configurations with highest standard deviation in table 2 are shown in Fig. 12.

Table 1
Comparative analysis of EGWO, GWO and PSO MPPT algorithms

PV Configuration	Shading Pattern	Tracking algorithm	Power (W)	Voltage (V)	Current (A)	Duty ratio ($d_{optimal}$)	Tracking time (sec)	Maximum Power from P-V curve	Efficiency (%)
4S	1	EGWO	522.633	110.02	4.75	0.5195	3.6	522.6331	99.99
		GWO	522.633	110.02	4.75	0.5183	8.2		99.99
		PSO	522.633	110.02	4.75	0.5191	11.7		99.99
	2	EGWO	401.064	52.28	7.67	0.7391	4.8	401.0647	99.99
		GWO	401.064	52.49	7.64	0.7378	8.4		99.99
		PSO	401.064	52.49	7.64	0.7378	12.3		99.99
	3	EGWO	270.090	84.14	3.21	0.4882	5.9	270.1204	99.98
		GWO	270.120	84.14	3.21	0.4883	9.2		99.99
		PSO	270.120	84.14	3.21	0.4874	12.1		99.99
2S2P	4	EGWO	523.078	54.95	9.52	0.7583	4.5	523.1240	99.99
		GWO	523.078	55.06	9.50	0.7592	8.2		99.99
		PSO	522.93	54.70	9.56	0.7608	13.2		99.96
	5	EGWO	401.185	26.12	15.36	0.8696	3.5	401.3190	99.96
		GWO	401.199	26.36	15.22	0.8684	7.7		99.97
		PSO	353.425	55.57	6.36	0.7043	10.9		88.06
	6	EGWO	437.95	55.17	7.94	0.7363	3.7	438.0498	99.97
		GWO	437.97	55.37	7.91	0.7354	7.9		99.97
		PSO	437.97	55.37	7.91	0.7353	11.8		99.97

Table 2
Statistical comparative analysis of EGWO, GWO and PSO MPPT algorithms

PV configuration	Shading pattern	Tracking method	Mean best values (W)	Standard deviation (W)	Maximum power value (W)	Minimum power value (W)	Average tracking time(s)
4S	1	EGWO	522.633	522.582	522.629	0.0082	3.6
		GWO	522.633	522.622	522.632	0.0021	8.2
		PSO	522.633	401.064	517.768	24.0638	11.7
	2	EGWO	401.064	400.064	401.044	0.0704	4.8
		GWO	401.064	352.932	399.134	11.5464	8.4
		PSO	401.064	352.932	390.473	21.8291	12.3
	3	EGWO	270.120	270.034	270.115	0.0148	5.9
		GWO	270.120	270.090	270.119	0.0042	9.2
		PSO	270.120	261.316	268.887	3.0858	12.1
2S2P	4	EGWO	523.124	520.826	522.763	0.4442	4.5
		GWO	523.124	522.358	523.033	0.1325	8.2
		PSO	523.124	522.785	523.073	0.0666	13.2
	5	EGWO	401.319	400.294	401.027	0.2344	3.5
		GWO	401.319	400.896	401.182	0.1465	7.7
		PSO	401.319	353.052	371.559	24.0344	10.9
	6	EGWO	438.049	437.144	437.692	0.2295	3.7
		GWO	438.049	437.658	437.658	0.1151	7.9
		PSO	438.049	437.049	437.957	0.1230	11.8

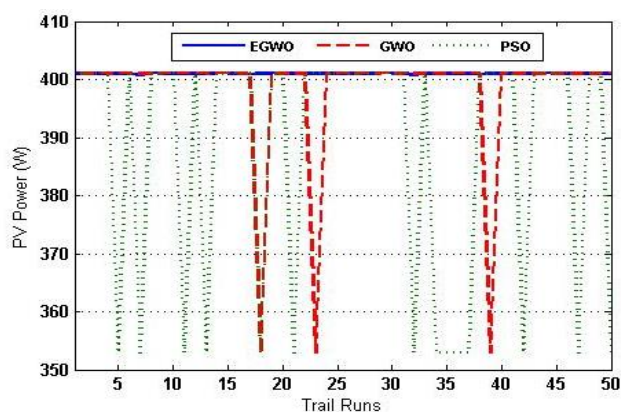

(a)

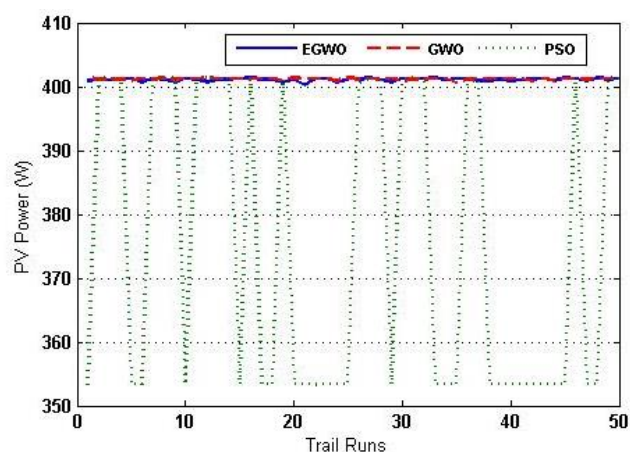

(b)

Fig. 12 Maximum power tracked by three algorithms for (a) Shading pattern 2 of 4S Configuration, (b) Shading pattern 5 of 2S2P Configuration

From Figure 12, it is observed that PSO MPPT algorithm suffers from local MPP trapping frequently and GWO MPPT algorithm suffers occasionally, whereas EGWO MPPT algorithm does not suffer from local MPP trapping and tracks the global MPP for all the trail runs performed

5. Conclusion

An accurate analytical modeling of PV system under partial shaded condition is presented. An Enhanced GWO MPPT algorithm is proposed by eliminating the δ and ω phase of conventional GWO algorithm to track the global MPP of PV system under partial shaded condition with more accuracy and in less tracking time. To examine the performance of the proposed EGWO algorithm, simulations are carried out on 4S and 2S2P PV configurations subjected to three different shading patterns. The dynamic performance of the proposed algorithm is observed by subjecting the 4S and 2S2P PV configurations for dynamically changing shading patterns each for 30 sec. The performance of proposed algorithm is examined by comparing results with existing

conventional GWO and PSO MPPT algorithms and results are presented. It is noticed that proposed algorithm tracks global MPP with more accuracy and less tracking time. Due to stochastic nature of heuristic algorithms, 50 trail runs were performed for three algorithms under similar conditions and it is observed that proposed algorithm is free from local MPP trapping and has less standard deviation than PSO MPPT algorithm, less tracking time than GWO and PSO MPPT algorithms. From performance analysis, it is observed that proposed EGWO algorithm is superior to other two algorithms.

Appendix

Table A

Parameters of Kyocera KC-200GT module

Maximum power (P_{mp})	200 W
Open circuit voltage (V_{oc})	32.9 V
Short circuit current (I_{sc})	8.21 A
Maximum power Voltage (V_{mp})	26.3 V
Maximum power current (I_{mp})	7.61 A
Voltage temperature coefficient (k_v)	$-1.23 \times 10^{-1} \text{ V}^\circ\text{C}$
Current temperature coefficient (k_i)	$3.18 \times 10^{-3} \text{ A}^\circ\text{C}$

Table B

Parameters of EGWO, GWO and PSO MPPT algorithms

Parameter	PSO	GWO	EGWO
Initial population (duty ratio)	Randomly between 0.1 and 0.9	Randomly between 0.1 and 0.9	Randomly between 0.1 and 0.9
N_p	4	4	4
$C_{1,max}$	2	-	-
$C_{2,max}$	2	-	-
$C_{1,min}$	1	-	-
$C_{2,min}$	1	-	-
W_{max}	1	-	-
W_{min}	0.1	-	-
Maximum number of iterations, t_{max}	100	100	100
Termination criteria	t_{max}	t_{max}	t_{max}

References

Ahmed, J. and Salam, Z. (2014) A maximum power point tracking (MPPT) for PV system using Cuckoo search with Partial shading capability. *Appl Energy*, 119, 118-130.

Ciulla, G., Brano, V.L., Dio, V.D. and Cipriani, G. (2014) A comparison of different one-diode models for the representation of I-V characteristic of a PV cell. *Renewable and sustainable energy reviews*, 32, 684-696.

Gupta, A., Chauhan, Y.K and Rupendra, K.P. (2016) A comparative investigation of maximum power point tracking methods for solar PV system. *Solar energy*, 136, 236-253.

Ishaque, K., Salam, Z., Amjad, M. and Mekhilef, S. (2012) An improved particle swarm optimization (PSO)-based MPPT

- for PV with reduced steady state oscillations. *IEEE Trans Power Electron*, 27(8), 3627-3637.
- Ishaque, K., Salam, Z., Shamsudin, A. and Amjad, M. (2012) A direct control based maximum power point tracking method for photovoltaic system under partial shading conditions using particle swarm optimization algorithm. *Applied Energy*, 99, 414-422.
- Jiang, L.L., Maskell, D.L. & Patra, J.C. (2013) A novel ant colony optimization based maximum power point tracking for photovoltaic systems under partially shaded condition. *Energy & Buildings*, 58, 227-236.
- JNNSM, India. (2016) <http://www.mnre.gov.in>.
- Jordehi, A.R. (2016) Maximum power point tracking in photovoltaic (PV) systems: A review of different approaches. *Renewable and sustainable energy reviews*, 65, 1127-1138.
- Kumar, C., & Rao, R. (2016). (2016). A Novel Global MPP Tracking of Photovoltaic System based on Whale Optimization Algorithm. *International Journal of Renewable Energy Development*, 5(3), 225-232.
- Liu, Y.H., Huang, S.C., Huang, J.W. and Liang, W.C. (2012) A particle swarm optimization based maximum power point tracking algorithm for PV systems operating under partially shaded conditions. *IEEE Trans Energy Conv*, 27(4), 1027-1035.
- Mirjalili, S., Mirjalili, S. M. & Lewis, A. (2014) Grey wolf optimizer. *Advances in Engg Software*, 69, 46-61.
- Ramli., M.A.M., Twaha,S., Ishaque, K. and Al-Turki, Y.A.. (2017) A review on maximum power point tracking for photovoltaic systems with and without shading conditions. *Renewable and sustainable energy reviews*, 67, 144-159.
- Sangram, B. and Saini, R. P. (2016) A mathematical modeling framework to evaluate the performance of single diode and double diode based SPV systems. *Energy reports*, 2, 171-187.
- Saravanan, S. and Ramesh, B., N. (2016) Maximum power point tracking algorithms for photovoltaic system – A review. *Renewable and sustainable energy reviews*, 57, 192-204.
- Satyajit, M., Bidyadhar, S. and Pravat, K.R. (2016) A new MPPT design using grey wolf optimizer technique for photovoltaic system under partial shading conditions. *IEEE Trans on sustainable energy*, 7(1), 181-188.
- Silvestre, S., Boronat, A. and Chouder, A. (2009) Study of bypass diodes configuration on PV modules. *Applied Energy*, 86, 1632-1640.
- Sundareswaran, K., Sankar, P. and Sankaran, P. (2014) MPPT of PV systems under partial shaded Conditions through a colony of flashing fireflies. *IEEE Trans Ener Conv*, 29(2), 463-472.
- Sundareswaran, K., Sankar, P., Nayak, P.S.R., Simon, S.P. & Palani, S. (2015) Enhanced energy output from a PV system under partial shaded conditions through Artificial bee colony. *IEEE Trans Sustainable Ener*, 6(1), 198-209.
- Verma, D., Nema.S., Shandilya, A., M., and Dash, S.K. (2016) Maximum power point tracking (MPPT) techniques:Recapitulation in solar photovoltaic systems. *Renewable and sustainable energy reviews*, 54, 1018-1034.
- Zainal, S., Jubaer, A. and Beny, S.M. (2013) The application of soft computing methods for MPPT of PV system: A technological and status review. *Applied Energy*, 107, 135-148.