



Contents list available at IJRED website

Int. Journal of Renewable Energy Development (IJRED)

Journal homepage: <http://ejournal.undip.ac.id/index.php/ijred>



Review Article

A Review on Solar PV Based Grid Connected Microinverter Control Schemes and Topologies

Manoharan Premkumar^{a*}, Kanagarathinam Karthick^a, Rayichandran Sowmya^b

^aDepartment of Electrical and Electronics Engineering, GMR Institute of Technology, Rajam, Andhra Pradesh 532127, India

^bDepartment of Electrical and Electronics Engineering, National Institute of Technology, Tiruchirapalli, Tamilnadu, India

ABSTRACT. From the last decade, there is an increase in the demand of electricity, this will causing depletion in the fossil fuels which results increase in cost. So the focus is shifted to use of renewable energy sources along with the only utility grid but it is not sufficient to supply the power different loads. To overcome these problems, micro-grid (MG) is introduced and it is powered by renewable distributed generation (DG) systems, such as, micro turbines, fuel cells, solar photovoltaic (PV) and wind generation due to the limited fossil fuel. Out of the above sources, solar energy provides extraordinary benefits including environmental friendly, surplus availability and low installation cost due to the advanced technology and mass production. The solar grid connected micro inverters gain lot of intention in past few years due to its simple construction, reliability and durability. Moreover, the grid connected micro inverter has high reliability and it can operate in abnormal conditions also like variations in voltage and current. The micro-inverter has attracted recent market success due to unique features such as lower installation cost, improved energy harvesting, and improved system efficiency. This article gives detailed review on different topologies for grid connected solar PV micro-inverter and suggests the reliable, suitable and efficient topology for micro-inverter.

Keywords: Micro-grid, Distributed generation, Solar PV, Grid Inverter, Micro-inverter, Reliability

Article History: Received Dec 16th 2017; Received in revised form May 14th 2018; Accepted June 1st 2018; Available online

How to Cite This Article: Premkumar, M., Karthick, K and Sowmya, R. (2018) A Review on Solar PV Based Grid Connected Microinverter Control Schemes and Topologies. *Int. Journal of Renewable Energy Development*, 7(2), 171-182.
<https://doi.org/10.14710/ijred.7.2.171-182>

1. Introduction

Solar photovoltaic (PV) conversion gained lot of importance from the past decade, due to grid connection of these solar PV micro inverters there will be advantage than the stand-alone systems. As per the statement of (Predeepkumar et al. 2015), in the past few years, solar energy sources demand has grown consistently an annual growth rate of over 25%. Also, due to grid connection the overall efficiency of the system increases and losses will be reduced. For smaller area, residential and commercial applications. PV micro inverters are attractive and are a focus of extensive research in both academia and industry. From the study of Hu et al. (2013); Yue et al. (2015); Woo-Jun et al. (2015); Shibin et al. (2016); Arunmozhi and Arokiaraj, (2016), the size of the micro-inverter can be reduced by increasing its switching frequency. However, to maintain or enhance efficiency at the higher switching frequencies, advanced topologies and control strategies are necessary.

The two main classifications of the PV systems are the stand-alone and grid-connected systems is discussed by Jason and Vieri, (2013); Premkumar et al. (2014); Thang et al. (2014); and Baojian et al. (2015). However, the

hybrid grid connected systems are of significant value for managing power locally. To maximize the power utilization of PV system, proper power conditioning units are required. Arunmozhi et al. (2016) stated that, to synchronize the PV system to the grid, a proper DC-AC inverter is required, which should be capable of bi-directional power flows to charge and discharge the battery as per the load requirements. According to Tirthasarathi et al (2016) when a PV system is connected to the utility grid, it might deliver excess PV output with respect to the load and battery capacity to the grid or use the grid as a backup system, in the case of insufficient PV generation.

Premkumar et al. (2016) and Premkumar et al. (2018) discussed various MPPT and by using MPPT algorithms the output voltage can be increased. Pradeep and Baylon (2017) proposed a different fault tolerant topology may be used for reduction in faults. Since maximum PV inverters used in household applications in order to lower the system prices, isolation transformers used in the past to interface the PV-system with the electric grid in order to provide higher safety and lower leakage current, is typically not present in the new generation of PV-systems. Meneses et al. (2013); Baifeng et al. (2015); and Woo-Jun

* Corresponding author: mprem.me@gmail.com

et al. (2015) discussed many transformerless topology to increase the stability of the inverter. In this topic, the paper deals about different control strategies and topology of grid connected PV systems.

2. Solar PV Characteristics in Uniform and Non-Uniform Irradiation

As per statement from Irtaza and Kaamran (2015), solar photo voltaic (SPV) is considered to be a significant energy source since it is renewable and it produces clean and green energy. The V-I characteristics of a PV panel is a non-linear that needs correct identification of optimum operating point. The output power of SPV panel varies with respect to temperature and insolation. For economic operation, it is desired to operate SPV module at its maximum power output. To draw maximum energy from the panel, the panel internal resistance should be equal to load resistance.

Umashankar et al. (2016) and Srinivas and Ramesh (2014) discussed that DC-DC converter is intervened between SPV and the load to adjust the load resistance by SPV equal to the internal resistance by varying the duty cycle of the converter. There are many maximum power point tracking (MPPT) method are available in practice. The major challenge of using SPV source containing a number of cells in series and it is to deal with its nonlinear internal resistance.

The heat on the SPV will increase when the cells are under shade which will absorb more amount of electric power and it receive high insolation and convert it into heat. This high temperature may damage the low illuminated PV cells under certain conditions. The bypass diodes are added across the modules to relieve the stress on shaded cells. The equation 1 need to be satisfied during partial shading on SPV.

$$V_{pv} = \sum_{i=0}^n V_i \geq V_{D_0} \quad i \neq 2 \quad (1)$$

Where, V_{D_0} is the forward voltage drop of the diode. Due to shading, multiple peaks are observed under non-uniform illumination. The effect of the irradiance and temperature on the voltage-current (V-I) and voltage-power (V-P) characteristics is depicted in figure 1. As photo-generated current is directly proportional to the irradiance level, so an increment in the irradiation leads to a higher photo-generated current. Moreover, the short circuit current is directly proportional to the photo generated current; therefore it is directly proportional to the irradiance. When the temperature increases, the voltage decreases. The current increases with the temperature but less in magnitude and it is not enough to compensate the decrease in the voltage caused by temperature rise. So that, the power also decreases. PV panel manufacturers provide in their data sheets the temperature coefficients, which are the parameters that identify how the open circuit voltage, the short circuit current and the maximum power vary when the temperature changes.

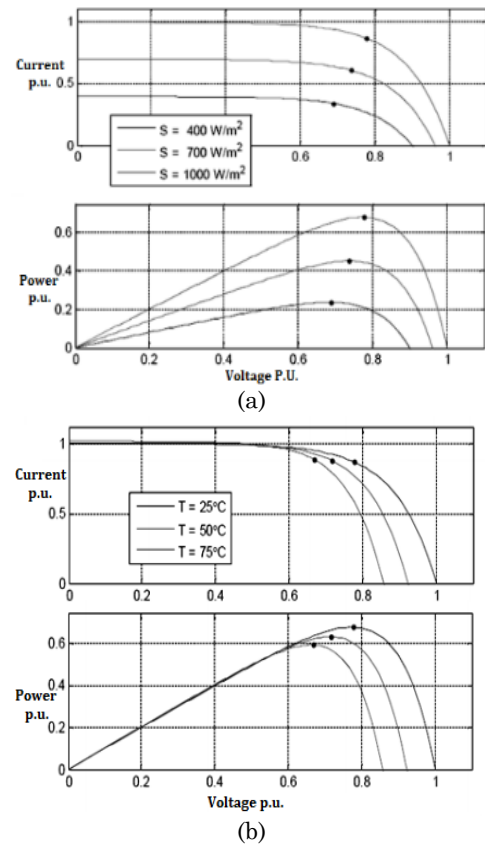

Fig. 1 V-I and V-P curves (a) Constant temperature and different insolation levels; (b) constant irradiation and different temperatures

The both temperature and the irradiation depends on the atmospheric conditions, which are not constant during a single day; they can differ due to varying conditions such as clouds. This causes the MPP to vary continuously depends on the irradiation and temperature. If the point is not close to the MPP, more power losses may occur. Hence, it is essential to track the MPP at any conditions to assure that the maximum power is obtained from the SPV panel. In solar power converter, this task is entrusted to various MPPT algorithms. The conventional MPPT methods are not effective due to inability to separate between local and global maximum. The new optimization technique along with traditional MPPT methods will solve the above said problem. However, it is necessary to understand the characteristics of the SPV under partially shaded conditions.

3. Different Solar PV Inverter Topology

3.1 DC/AC converter for grid connected operation

Pradeep et al. (2015) presented modeling and control of single phase grid connected two stage micro inverter system. It has 3 cascaded control loops. This model is applied to 500 Watts, 50Hz, two stages, single phase, grid connected PV system. It mainly consists two stages. First stage is the dc-dc power stage. It extracts maximum power from the PV cells and the second stage generates a synchronized sinusoidal current and it generates to the grid with unity power factor.

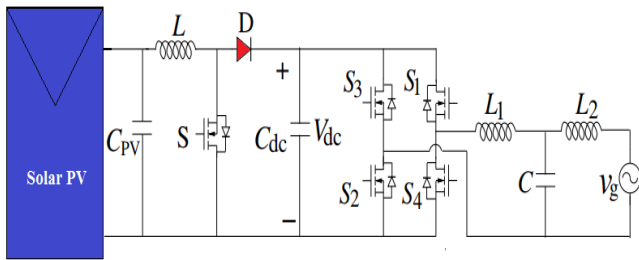

Fig. 2 DC/AC converter for grid connected operation (Pradeep et al. 2015)

The two-stage topology is presented in figure 2. It mainly consists of a PV module, two capacitors, inductor, and diode in input circuit. The dc link capacitor Cdc is used to keep the input voltage of inverter constant. Inverter is connected with the grid by inductor L2, where the high frequency switching harmonics are suppressed by the LC filter of inductance L1, and capacitance C. The dc link voltage is regulated with a level higher than the peak voltage of the grid.

The controller has three cascaded control loops. The inner current loop consists of a variable frequency hysteric current mode control which regulates output filter inductor current thereby improved system response. The dynamic performance of the system is improved by introducing the inner current loop. In order to use the PI regulator of the grid current control in the second loop, a small signal equivalent circuit of single-phase bridge inverter is derived based on average signal model.

3.2 Single stage multi-port converter based micro-inverter

Kyritsis, et al. (2008), Zhang, et al. (2010), Nanakos et al. (2012), Kim et al. (2013) and Tirthasarathi et al. (2016) proposed a single stage multi-port converter and control based on fly-back principle for solar PV module integrated micro-inverter application. The topology provides galvanic isolation between solar PV, battery, and the load and achieves high voltage gain. Moreover, the battery does not have to handle the 100 Hz ripple power required by the AC load, neither during the day mode or the night mode. No additional circuitry is required to achieve this objective during night mode. All these features along with the power conversion in a single stage, lead to higher efficiency and significantly improve the battery life.

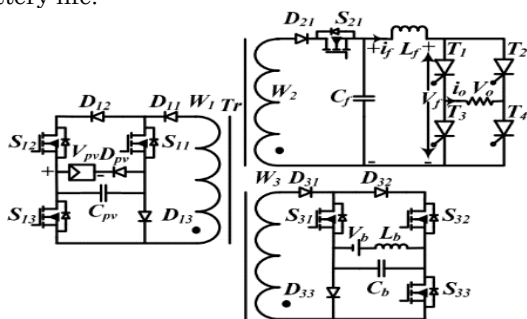

Fig. 3 Single stage multi-port converter based micro inverter (Zhang et al. 2010)

The multi-port topology is shown in figure 3. The power conversion will take place in single stage. It consists of a Flyback dc to dc converter, L-filter and an unfolding circuit (SCR based inverter). Tr is the Flyback transformer, consisting of three windings (W1, W2, W3).

The switching frequency of the proposed topology is 40 kHz. Maximum Power Point Tracking (MPPT) of PV module, as well as the voltage control across the connected load, is implemented by controlling the peak current reference of the PV side and battery depending upon the different operating condition.

3.3 A Forward micro inverter with primary-parallel secondary-series transformer

Ognjen et al. (2015) and David et al. (2015) presented a primary-parallel secondary series multicore forward micro inverter for photovoltaic ac-module application. The presented micro inverter operates with a constant off-time boundary mode control, providing MPPT capability and unity power factor. The multi transformer solution allows using low-profile unitary turns ratio transformers. Therefore, the transformers are better coupled and the overall performance of the micro inverter is improved. The inverter topology is shown in Figure 4.

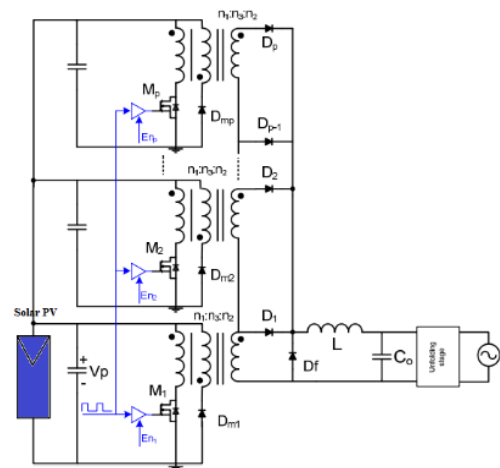

Fig. 4 Forward microinverter with primary-parallel secondary-series transformer (Meneses et al. 2013)

In this configuration, the primary of transformer is connected in series and the secondary side of transformer is connected in parallel. The series connection improves voltage and the parallel connection reduces current stresses. The voltage gain is given in equation 2.

$$V_o = n * m * d * V_p \tag{2}$$

Where, m is the no of active phases, Vp the PV panel voltage, d the applied duty cycle and n is the primary to secondary turn's ratio (n2/n1) of each transformer. In this topology, an increase in the number of transformers allows the utilization of better coupled transformers, improving the inverter performance.

3.4 Grid-tie solar inverter with a series voltage compensator

Arunmozhi et al. (2016) described the series compensation method-based energy management at micro grid. A series compensator is attached to series with the power supply. In this model, a trail model of 500W, 230V and 50Hz has been evaluated. It mainly consists of power assistant circuit, series voltage compensator, boost converter and dc-ac converter. The series voltage compensator gets the energy from power assist circuit

without isolation problems. It will perform depending on the input voltage and output voltage variations. As the compensator produces both positive and negative voltage which evaluates the step-up and step-down mode operation. The input dc voltage is equal to the average voltage V_{dc} . By using this circuit configuration, high output voltage and efficiency will be achieved. The series compensator plays a very important role to balance the voltages.

3.5 Double-stage single-phase grid-connected photovoltaic (PV) system operating with an additional feed-forward control loop (FFCL)

The FFCL was proposed by Sergio et al. (2017) to improve the DC-bus voltage dynamic response and reduce the settling time and overshoot. Also, the system is affected by mismatching phenomenon such as partial shading. So, particle swarm optimization (PSO) is used as MPPT. Here, DC-DC buck boost converter is used for MPPT operation.

In this model, the current reference generator calculates the reference current and it is synthesized for grid connected systems therefore, the inverter current is composed of the following components: (i) Active component, which is proportional to the energy produced from the PV array; (ii) Reactive component, which is proportional to the load reactive power compensation; and (iii) Harmonic components, which depend on the nonlinear characteristics of the load. The current given to the grid consists of both active and reactive and harmonic components. DC bus feed forward control loop is used to reduce amplitude oscillations that can occur in the DC-bus voltage due to the occurrence of disturbances, such as abrupt solar radiation change.

The FFCL is based on the DC-bus power balance. Although maintaining the DC-bus voltage by means of the DC-bus voltage controller can ensure PV system power balance, the referred controller is not fast enough to avoid voltage oscillations when sudden insolation changes occur. In other words, the voltage control loop must be adequately designed to be slower than the current control loop to guarantee no interference between the two control loops, which could affect the quality of the current waveform injected into the grid.

3.6 Grid tied photovoltaic cascaded H-Bridge (CHB) inverter with a mixed staircase PWM technique

Minjie et al., (2015), Coppola et al., (2016) and Premkumar et al. (2018) proposed advanced control strategy for grid tied photovoltaic cascaded H-Bridge inverter. The main advantages of the system are, (i) a modular structure able to be adapted to different voltage and power levels, thus allowing the sharing of voltage boosting among the cascade of the H bridge cells; (ii) a multilevel waveform expandable to a number of voltage steps depending on the number of used cells. The CHB with mixed staircase PWM based topology is shown in Figure 5.

In this type of connection, the output of each PV generator is connected to H bridge inverter. By using this connection, the output voltage will increase and also desired sinusoidal ac waveform produced. The increase in the number of voltage levels also allows to reduce the total harmonic distortion (THD), improving the quality of the

output voltages and currents with respect to conventional converters. As a result, harmonics reduces and overall efficiency increases. The modulation method is based on a mixed staircase-PWM is able to reduce the devices number in switching mode. This technique is properly adapted to the PV application in order to maximize the power extraction by guaranteeing the individual MPP tracking of each cell through a dedicated sorting algorithm.

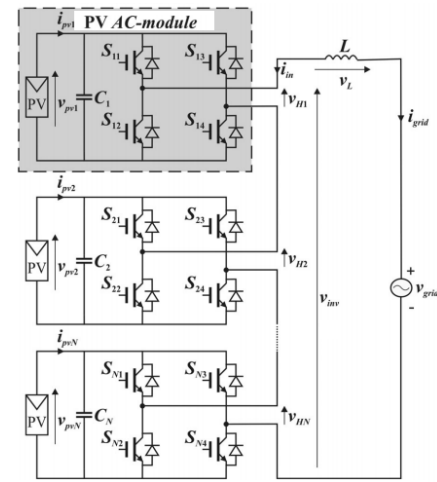

Fig. 5 Single phase grid-tied PV CHB inverter (Coppola et al. 2016)

3.7 PWM strategy for grid connected half-bridge active NPC converters with losses distribution balancing mechanism

Lin et al. (2015) proposed new PWM strategy for half bridge converter to get higher efficiency in the system, and the topology is named as neutral point clamped (NPC) topology. The topology is shown in figure 6.

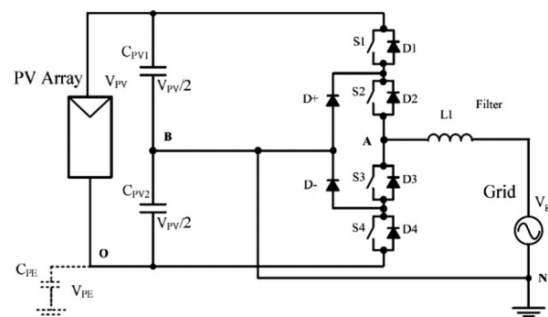

Fig. 6 Grid connected half-bridge active NPC converter(Lin et al. 2015)

The Figure 6 shows the active neutral point clamped half bridge converter which mainly consists of PV array, two capacitors, switches and diodes and inductor at the output circuit which will be connected to the grid. Two active switches with anti-parallel diodes are used for clamping. In contrast to the conventional NPC converter, it has more than one way to clamp the midpoint. The upper clamping path results from turning on S2 and S5 and the lower clamping path from turning on S3 and S6. The current can be conducted through both clamping ways in both directions.

By adopting adjustable losses distribution (ALD) strategy, the switching losses between inner switches and outer switches is distributed, however this will not distribute total losses. By using the pulse width modulation technique, the reference output voltage waveform is compared with the voltage of the NPC converter, by using this topology the switching paths can be decided and thus switching losses reduced.

3.8 High efficient micro inverter with soft-switching step-up converter and single switch modulation inverter

Woo-Jun et al. (2015a) proposed a high efficient DC-DC converter using active clamping circuit with a series resonant voltage doubler and a high efficiency inverter with single switch modulation converter. The active-clamp circuit provides zero-voltage switching (ZVS) turn-on, recycles the energy stored in the leakage inductance of the transformer, and limits switch voltage stress. Moreover, to remove the reverse-recovery problem of the rectifier diodes, a series-resonant voltage doubler is used. The single switch modulation inverter topology is shown in Figure 7.

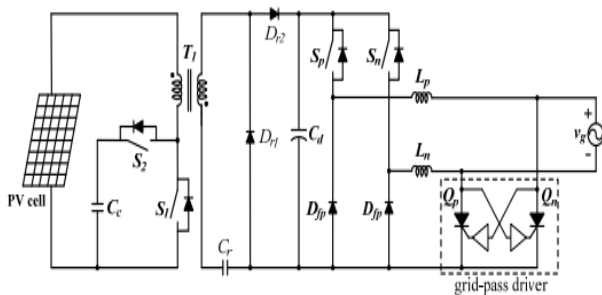

Fig. 7 Soft switching step up converter and single switch modulation inverter topology (Woo-Jun et al. 2015a)

The system mainly consists clamping circuit in the primary side and series-voltage doubler in the secondary side of the transformer T1. The active clamping circuit mainly consists of two switches S1 and S2 and a capacitor Cc. The circuit is used to limit the voltage across switch S1 and regenerates the energy stored in the inductor. In the secondary side the diodes Dr1 and Dr2 and capacitor Cr represents series resonant voltage doubler. By operating this inverter topology in different stages, it provides the resonant current paths of the power transfer regardless of the main switch state. In particular, resonant current formed by leakage inductance of the transformer and the resonant capacitor removes the reverse-recovery problem of the secondary rectifier diodes Dr1 and Dr2. The active-clamp circuit offers the soft switching of the primary side switches and reduces the voltage stress by clamping the voltage spike across the switches.

3.9 Solar grid interfaced system with active filtering using adaptive linear combiner filter

Guoping et al. (2015) and Yashi et al. (2017) provided a control scheme for single stage solar photovoltaic (SPV) grid-interfaced system. The voltage source inverter (VSI) is a power electronic interface between SPV array and the grid. To increase the utilization of VSI, it is used as an active power filter at night, to reduce harmonics and to provide active power to the load from the utility grid. The adaptive linear combiner filter has the capability to

extract harmonics and enhances the power quality in SPV grid-interfaced system. The inverter topology with active filtering is shown in Figure 8.

The solar photovoltaic grid-interfaced converters operate an average of 6–8 hours per day to generate the power. To make the solar energy conversion system cost effective with high utilization of its voltage-source inverter throughout day and night, an additional feature of active power filter (APF) included in the system. The SPV system combines with the features of APF performs elimination of harmonics current and to improve the power factor. Significantly, PV arrays can be utilized effectively, and power quality can be improved correspondingly.

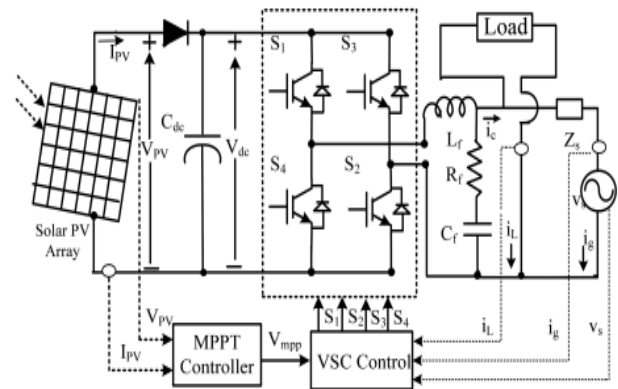

Fig. 8 Single phase solar grid interfaced system with active filtering (Yashi et al. 2017)

3.10 Single phase solar inverters by a variable frequency peak current controller

Yoash et al. (2016) discussed a control method that achieves high weighted efficiency in solar micro-inverters. The controller presents two primary benefits that enable such an efficiency profile, a switching frequency that scales with power, and a low peak current that enables efficient magnetic design of the inductor. At high powers, the switching frequency increases to minimize the RMS current, and at low powers, the switching frequency decreases to minimize the switching loss. Since the peak inductor current is low, the inductor may be designed with fewer turns of wire, or with lower flux density, and is thus highly efficient.

The constant peak current switching scheme is implemented by a cycle-by-cycle predictive controller that uses a fast integrator to control the switching period, achieving high bandwidth and stability. Micro-inverters usually operate either in Discontinuous Conduction Mode (DCM) or in Boundary Conduction Mode (BCM). This is primarily because the CCM method requires a large inductor and is hard switching, while DCM and BCM use smaller inductors and are soft switching. This scheme presents two main benefits, a switching frequency that scales with power, and a low peak current that enables efficient magnetic design of the inductor.

3.11 Fly-back PV micro-inverter and optimizing control system

Zhang et al (2013), Sukesh et al. (2014), Fongang et al. (2014) and Mahshid et al. (2015) had designed a micro-inverter in which a high speed MPPT algorithm is implemented in order to keep the reliability of the control

system. An optimizing method is applied to the interleaved micro-inverter, to minimize the error function as the cost function. The flyback inverter topology is shown in Figure 9.

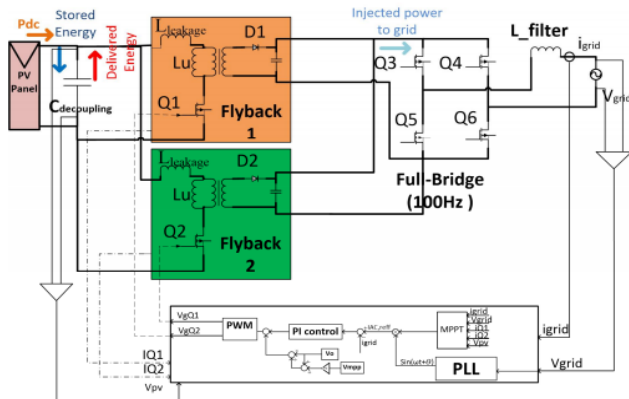

Fig. 9 Flyback micro-inverter topology (Mahshid et al. 2015)

In this technique, a control strategy to inject a sinusoidal current into the grid with unity power factor for fly-back micro-inverter was presented, which works in continuous condition mode (CCM) operation. Simple regenerative snubber was proposed to improve the efficiency of fly back micro-inverter without RCD snubber. The importance is because leakage inductance inside high-frequency transformer of the fly-back converter, stores leakage energy in every switching cycle. This energy cannot be transferred to the secondary and load side. Therefore, it must be wasted or brought back to the DC-Link. PI controller is often proper for step response because it leads steady state error to zero by integrating the error. By using finite gradient descent method, controller coefficients are designed, to minimize the error of injected current to the grid as the cost function.

3.12 Transformerless photovoltaic inverter topology for efficiency improvement and reduction of leakage current

Woo-Jun et al., 2015b) and Davide et al. (2016) proposed transformerless photovoltaic grid-connected inverter topology, to reduce leakage current and to increase efficiency. The H5 inverter topology is shown in Figure 10.

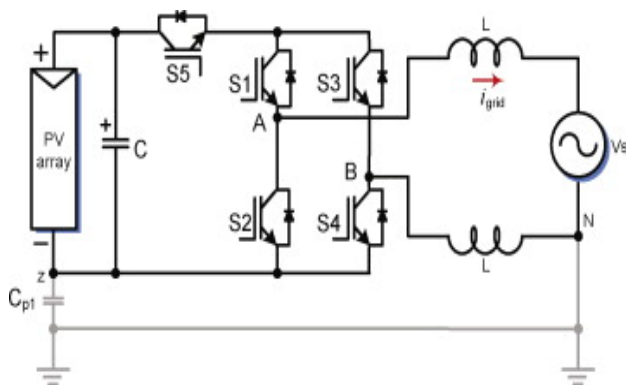

Fig. 10 H5 inverter topology with leakage current reduction (Woo-Jun et al. 2015b)

The topology consists of a full-bridge with an extra switch in the positive bus of the dc-link. The V_{ab} has the three-voltage levels including the zero output-voltage state. It leads to lower core losses and prevents the

reactive power exchange during the freewheeling operation. Moreover, this scheme has the low leakage current and EMI. However, three switches are conducting during the power generating, leading to higher conduction losses.

The leakage current may cause malfunctions in the circuit like shock to the human body. To reduce switching losses, the number of switches which operates with the high-frequency should be reduced and to reduce conduction losses, the number of switches in the current path should be reduced during the inverter operates. Also, there should be no high-frequency voltage in the parasitic capacitor to achieve the low leakage current.

3.13 Fault tolerant single-phase grid connected micro-inverter topology

Pradeep et al. (2017) proposed fault tolerant inverter topology to achieve the reliability on the converter. However, the reliability of inverters used in the PV system is mainly affected due to the vulnerability of power semiconductor devices to failure. The fault tolerant inverter topology is shown in figure 11.

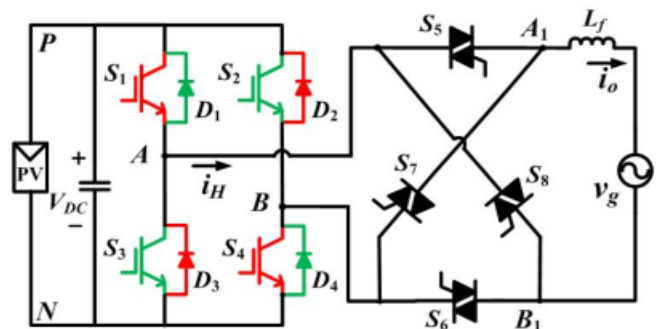

Fig. 11 Fault tolerant micro-inverter topology (Pradeep et al. 2017)

A single-phase fault-tolerant inverter topology is proposed, which does not use the redundant leg and achieves the fault-tolerant feature with minimal device count. When an open circuit fault occurs in S1 or S4, the converter continues to function using S2 and S3. In this case, the TRIACs S5 and S6 are kept on during negative half cycle, while S7 and S8 are kept on during the positive half cycle. The switching strategy for S2 and S3 is same as that of S1 and S4 during the normal operating condition. The powering mode is obtained by turning ON S2 and S3. During freewheeling mode, either D1 and S2, or S3 and D4 conduct. The TRIACs are turned OFF at every zero-crossing instant of current; hence the natural commutation is retained even in this case.

The inverter is reconfigured to conventional VSI in case of a fault in any one of the TRIACs. The switches S1-S4 are made to function like the conventional VSI, and the TRIACs are either turned ON or turned OFF permanently. A similar strategy is followed for SC fault in the other TRIACs. If a SC fault occurs in S7, S8 is turned ON and S5 and S6 are turned OFF permanently. The circuit is permanently reconfigured to the conventional VSI.

As discussed above, comparison of various micro-inverter topologies of SPV system is given in Table 1. Merits and demerits of different topologies and control schemes are presented in Table 2.

4. Modern SPV Circuit Topologies

4.1 High efficiency two-stage inverter for SPV grid connected systems

Lin et al. (2015), Yoshiya et al. (2015) and Jiang et al (2017) proposed two-stage converter for single-phase PV grid-connected inverters. It consists of a boost converter in the first stage and a buck converter in the second stage. The photovoltaic array and decoupling capacitors are treated as an integral direct current source (DCS) that provides an input voltage for the converters. The energy from the DCS is transmitted for the unit power factor grid-connected generation system. In the inverter topology, two independent units for the boost converter and buck converter are divided by the input voltage from the DCS. When the input voltage is below the absolute value of the grid voltage, the inverter works as a boost converter. Contrarily, the inverter works as a buck converter. Moreover, a bypass diode is used to provide a direct current branch for the buck converter in the second-stage.

4.2 Quasi single-stage buck-boost inverter

Keshav and Amod (2014), Tarek et al. (2015) and Ashraf et al. (2017) proposed a novel high efficiency quasi single-stage single-phase buck-boost inverter. The inverter can solve current shoot-through problem and eliminate PWM dead-time, which leads to greatly enhanced system reliability. It allows bidirectional power flow and can use MOSFET as switching device without body diode conducting. The reverse recovery issues and related loss of the MOSFET body diode can be eliminated. The use of MOSFET contributes to the reduction of switching and conduction losses. The inverter takes the dual-buck structure at the input dc side and the switching cell structure at the ac output side. It is immune from both short-circuit and open-circuit problems. Therefore, PWM dead-times can be eliminated in buck-boost inverter, which results in high quality output voltage waveforms. Moreover, it utilizes high speed power MOSFETs along with externally selected fast recovery diodes, which decrease the switching and conduction losses. Thus, high frequency and high efficiency operation is realized.

4.3 Cuk derived transformerless common grounded PV micro-inverter

Vasav et al. (2017) proposed CUK derived inverters, employing second order input and output filters, offer the most efficient, lightweight and economical solution in the class. The design and detailed operation of a Cuk derived from common-ground PV micro-inverter in continuous conduction mode operation. The inverter is compatible with both linear and non-linear loads, in stand-alone and grid connected modes of operation. The circuit does not require any common-mode noise filter. The negative conductor and grid neutral are shorted to ensure common grounding hence reduced or no common mode ground current. In grid connection mode of operation, earth connection is provided through grid neutral, whereas in stand-alone mode the negative rail is earthed to avoid runaway potential at the circuit nodes. Output voltage THD in stand-alone operation and output current in grid-connected mode are both shown to satisfy IEEE 519-2014

stipulations. The topology returns the most competitive efficiency than another conventional inverter topology.

4.4 Flyback microinverter for grid connected PV system

Gao et al., (2014) and Rasedul et al. (2017) proposed a high efficiency DC-DC flyback converter with a resonant full-bridge inverter to use in PV systems. The flyback converter is composed of a resonant active-clamp circuit that limits the voltage stress and provides zero voltage switching turn-on and turn-off of the power switches. Therefore, the switching losses of the high frequency primary switches are negligible. A resonant full bridge inverter with ZVS of the high frequency switches is adopted to make the overall efficiency high. The two-stage operation is performed with an active-clamp resonant flyback DC-DC converter and a resonant full-bridge inverter. The active-clamp resonant circuit confirms the ZVS operation of the high frequency switches of the flyback converter. Moreover, the rectifier diode is also operated in ZCS turn-off condition. A resonant branch consists of a switch parallel to an inductor provides the soft switching of the full-bridge inverter. The high voltage DC link allows the placement of small value film capacitor that has a high lifetime comparable to PV panel.

5. Recommendations and future direction

The grid connected microinverter should be compact and it should have fewer components and highly efficient with a reliable control algorithm to achieve the grid connected microinverter practical implementation. In section 5, the various selection criteria for the topologies, switches, transformers/transformerless, and the operation modes are discussed.

5.1. Inverter topology selection

Single stage inverter topology having less input capacitors because of power decoupling circuit and to improve the efficiency, soft switching is recommended. Soft switching will give better efficiency with interleaved flyback topologies but it requires power decoupling circuit to increase the life span. The other important topology is multi-stage topology and it has longer lifespan but it has the limitation of extended cost. So, the multi-stage topology with good efficiency and low number of circuit components is preferred for microinverter. To achieve soft switching with few components, the active clamp circuit should be placed in the primary and a resonant circuit in the secondary is a better solution.

5.2. Power switch selection

Both MOSFET and IGBTs are used to design the power circuit for microinverter. If the inverter is designed for medium power and fast acting, MOSFET is preferred, whereas IGBTs for low power and high-frequency applications. To reduce the switching loss in MOSFET at high frequency switching, fast acting switches like GaN or SiC power devices may be recommended. The new switching devices like SiC or GaAs Schottky diode may be selected to reduce the losses in the diodes when it is operating at high frequency due to their low forward voltage and reverse recovery behavior (Chengshan et al. 2013).

Table1.

Comparison of various grid connected microinverter

Name of the Technique	Publication Year	Strategy of Control	Cost	Application
Conventional Bridge Inverter	2015	Hysteresis Current Control	Low	DC-AC & DC-DC
Single Stage Multi-Port Converter	2012, 2013, 2016	Flyback Control	Medium	DC-AC
Forward Microinverter With Primary-Parallel Secondary-Series Transformer	2015	Constant Off-Time Boundary Mode Control	High	DC-AC & DC-DC
Inverter with Series Voltage Compensator	2016	Series Compensation	Medium	DC-AC
Double-Stage Single Phase Grid Inverter	2017	Feed Forward Control Loop	High	DC-AC & DC-DC
Cascaded H-Bridge (CHB) Inverter	2015, 2016, 2018	Mixed Staircase PWM	Low	DC-AC
Grid Connected Active NPC Converters	2015	Losses Distribution Balancing Mechanism	High	DC-AC
Efficient Grid Connected Single Phase PV	2014	SRF based Estimation	High	DC-AC & DC-DC
Single Switch Modulation Inverter	2015	Active-clamp Circuit based soft switching	Medium	DC-AC & DC-DC
Solar Grid Interfaced with Active Filtering	2017	Adaptive Linear Combiner Filter based Control	Low	DC-AC
Efficiency in Single Phase Inverters	2016	Variable Frequency Peak Current Controller	Medium	DC-AC
Fly-Back PV Micro-inverter	2013, 2014, 2015	Finite Gradient Descent Method	High	DC-AC & DC-DC
Transformerless Photovoltaic Inverter	2015	Leakage Current Analysis and High Frequency Model	Medium	DC-AC
Fault Tolerant Single-Phase Grid Connected Inverter	2017	Redundant Leg Based Control	Low	DC-AC

Table 2.
Merits and demerits of different topology

Name of the Technique	Merits	Demerits	Efficiency
Conventional Bridge Inverter	Harmonics and voltage unbalances are reduced	Due to dc link voltage, input power quality changes	96.45 %
Single Stage Multi-Port Converter	High voltage gain and galvanic isolation. It is single stage conversion	Less reliable and ripple formed in the circuit itself and less performance	97.88 %
Microinverter With Primary - Parallel Secondary - Series Transformer	THD reduced and the quality of the output voltage increases	Circuit is somewhat complex to design and implement	90.9 %
Solar Inverter with Series Voltage Compensator	Power loss reduces and efficiency increases	Operation is bit difficult to achieve the proper output waveform	98.23 %
Double-Stage Single Phase Grid Inverter	Overshooting and settling time reduced	Oscillations around the MPP in both transient and steady state operations	97.22%
Cascaded H-Bridge (CHB) Inverter	Increase in voltage levels allows to reduce THD, improving the quality of the output voltages and currents	More switching losses produced during operation	99%
Grid Connected Half-Bridge Active NPC Converters	Have low leakage current and high efficiency	Unequal distribution of losses in switching devices and leads to an unequal temperature	98%
Power Efficient Grid Connected Single Phase PV System	Better THD, less stress on electronic components and reduced switching losses	Two level converters will supply very high ground leakage currents	97%
Single Switch Modulation Inverter	Inverter will recycle the stored energy from the leakage inductance, and limits the voltage stress	Switching losses will be more and performance will be affected	96.2%
Solar Grid Interfaced with Active Filtering	Full utilization and it supplies the quality power to load & grid and it shows fast response	Use of bulky transformer reducing efficiency of the system	98%
Weighted Efficiency in Single Phase Solar Inverters	Achieving high bandwidth and good stability	Switching losses will be produced	99.15%
Fly-Back PV Micro-inverter	Steady state errors will be reduced	High voltage gain needed	98.75%

5.3. Magnetic Core Selection

If variation of flux density is more, the core loss will be more, which reduces the efficiency of the transformer. In single stage microinverter, the flyback converter of 100-200W with 10-50 kHz switching frequency, ETD and PQ cores may be used (Anastasios et al. 2015). But, for the multi-stage microinverter, PQ and RM cores are recommended with an optimized volume and cross-sectional area rated up to 300 W with a switching frequency of 40–100 kHz.

5.4. Operating Mode Selection

As per discussion from Hong al. (2015), DCM and BCM modes are preferred for micro-inverter since it requires small inductor and soft switching. The most of the microinverters are designed up to 100W and sometimes up to 250W. So, DCM operation is recommended for low-power microinverters. The control scheme in DCM is model predictive control and it would be a good solution for the 100W topology. Single- and two-phase splitting DCMs are preferred for 100–200W flyback microinverters. The flyback converter, which is rated more than 200 W, can be operated in BCM or a combined operation of DCM and BCM. The DC–DC converter in multi-stage topologies is better to operate in CCM to achieve more efficiency.

5.5. Grid Standard Maintenance

To achieve low total harmonic distortion, LC/LCL grid filters are recommended because, the filter offers good output power quality with less power losses. Reactive power injection control will be the added advantage of good PV system utilization and control of the grid voltage properly, especially in the low voltage grid. The islanding detection technique need to be selected properly to increase the stability of the PV system when the inverter topology is connected with the grid.

6. Conclusion

Grid connected microinverter topology discussed in this study has been proven that it is different among the other PV converter topologies because it offers high output power quality and reports safety related issues. Many researchers has been proposed varieties of research in recent publications to improve reliability, compactness, efficiency, and cost of the microinverter topology. At present condition, the PV inverter has to be disconnected from the grid when any abnormal/fault condition occurs. Thus, many control schemes has to be developed and investigated to make inverter operate between grid tied and islanding modes. Presently, the grid connected transformerless topologies are configured as high frequency transformerless topologies and low frequency transformerless topologies. Out of transformerless and transformer-based inverter topologies, transformer less topology has more advantages and has high maximum power point tracking, and both the topologies have high efficiency around 93 to 95%. In this article, study of three different grid connected inverter topologies such as transformerless inverter topology, low frequency transformer topology, and high frequency transformer inverter topology was conducted. This comparison shows

that transformerless inverter topology is the best choice for grid connected PV microinverter. A thorough study on different microinverter topologies will provide good reference for researchers to work on long lifespan, high efficiency, and low cost SPV converters.

References

- Anastasios, N., Georgios, C., & Emmanuel, T. (2015) Weighted Efficiency Optimization of Flyback Microinverter Under Improved Boundary Conduction Mode (i-BCM). *IEEE Transactions on Power Electronics*, 30(10), 5548-5564.
- Arunmozhi, R., & Arokiaraj, J. (2016) Series Compensation Technique Based Energy Management at Micro-grid. *Proceedings of International Conference on Emerging Trends in Engineering, Technology and Science, Chennai, India.*
- Ashraf, A.K., Honnyong, C., Hafiz, F.A., Juyong, K., & Jintae, C. (2017) A Highly Reliable and High Efficiency Quasi Single-Stage Buck-Boost Inverter. *IEEE Transactions on Power Electronics*, 32(6), 4185-4198.
- Baifeng, C., Bin, G., Lanhua, Z., Zaka, U.Z., Jih-Sheng, L., Zhiling, L., & Ruixiang, H. (2015) A High-Efficiency MOSFET Transformerless Inverter for Non-isolated Microinverter Applications. *IEEE Transactions on Power Electronics*, 30(7), 3610-3622.
- Baojian, J., Feng, H., Jianhua, W., & Shengming, H. (2015) A Dual Buck Three-Level PV Grid-Connected Inverter. *Journal of Power Electronics*, 15(4), 910-919.
- Chengshan, W., Yan, L., Ke, P., Bowen, H., Zhen, W., & Chongbo, S. (2013) Coordinated Optimal Design of Inverter Controllers in a Micro-Grid with Multiple Distributed Generation Units. *IEEE Transactions on Power Systems*, 28(3), 2679-2687.
- Coppola, M., Di, N.F., Guerriero, P., Iannuzzi, D., Daliento, S., & Del, P.A. (2016) An FPGA-based Advanced Control Strategy of a Gridtied PV CHB Inverter. *IEEE Transactions on Power Electronics*, 31(1), 806-816.
- David, M., Oscar, G., Pedro, A., Jesus, O., & Jose, C. (2015) Grid-Connected Forward Microinverter with Primary-Parallel Secondary-Series Transformer. *IEEE transactions on power electronics*, 30(9), 4819-4830.
- Davide, B., Emilio, L., Carlo, C., Giovanni, F., & Giampaolo, B. (2016) Recent Advances in Single-phase Transformerless Photovoltaic Inverters. *IET Renewable Power Generation*, 10(2), 260–273.
- Fongang, E., Xiao, W., & Khadkikar, V. (2014) Dynamic Modeling and Control of Interleaved Flyback Module-Integrated Converter for PV Power Applications. *IEEE Transaction on Industrial Electronics*, 61(3), 1377–1388.
- Gao, M., Chen, M., Zhang, C., & Qian, Z. (2014) Analysis and Implementation of an Improved Flyback Inverter for Photovoltaic AC Module Applications. *IEEE Transaction on Power Electronics*, 29(7), 3428-3444.
- Guoping, Z., Xinbo, R., Li, Z., & Xuehua, W. (2015) On the Reduction of Second Harmonic Current and Improvement of Dynamic Response for Two-Stage Single-Phase Inverter. *IEEE Transactions on Power Electronics*, 30(2), 1028-1041.
- Hong, L., Jun, W., Zhang, S., Ming, L., & Chaoran, F. (2015) Study on Improved DC Bus Series-Connection of Microconverter System. *Proceedings of Chinese Intelligent Automation Conference, Lecture Notes in Electrical Engineering*, 338, 571-579.
- Hu, H., Harb, N., Kutkut, N., Batarseh, I., & Shen, Z.J. (2013) A Review of Power Decoupling Techniques for Microinverters with Three Different Decoupling Capacitor Locations in PV Systems. *IEEE Transaction of Power Electronics*, 28(6), 2711–2726.
- Irtaza, M.S., & Kaamran, R. (2015) Alternating Current Photovoltaic Module Model. *World Academy of Science, Engineering and Technology-International Journal of*

- Electrical, Computer, Electronics and Communication Engineering, 9(3), 284-290.
- Jason, T., & Vieri, X. (2013) Grid-Connected Micro Solar Inverter Implement Using a C2000 MCU, Texas Instruments, Application Report, SPRABT0. 01-35.
- Jiang, L., Shanmei, C., & Anwen, S. (2017) A High Efficiency Two-stage Inverter for Photovoltaic Grid-connected Generation Systems. *Journal of Power Electronics*, 17(1), 200-211.
- Keshav, P., & Amod, C.U. (2014) High Step-Up Converters Based on Quadratic Boost Converter for Micro-Inverter. *Electric Power Systems Research*, 119(6), 168-177.
- Kim, Y.H., Ji, Y.H., Kim, J.G., Jung, Y.C., & Won, C.Y. (2013) A New Control Strategy for Improving Weighted Efficiency in Photovoltaic AC Module-Type Interleaved Flyback Inverters. *IEEE Transaction on Power Electronics*, 28(6), 2688-2699.
- Kyritsis, A.C., Tatakis, E.C., & Papanikolaou, N.P. (2008) Optimum Design of the Current-source Flyback Inverter for Decentralized Grid-connected Photovoltaic Systems. *IEEE Transaction on Energy Conversion*, 23(1), 281-293.
- Lin, C., Changsheng, H., Qian, Z., Kun, Z., & Issa, B. (2015) Modeling and Triple-Loop Control of ZVS Grid-Connected DC/AC Converters for Three-Phase Balanced Microinverter Application. *IEEE Transactions on Power Electronics*, 30(4), 2010-2023.
- Lin, M., Tamas, K., Pedro, R., Xinmin, J., Remus, T., & Marco, L. (2015) A New PWM Strategy for Grid Connected Half-Bridge Active NPC Converters with Losses Distribution Balancing Mechanism. *IEEE Transactions on Power Electronics*, 30(9), 5331-5340.
- Mahshid, K., Behzad, A., & Babak, F. (2015) Analysis of Fly-Back PV Micro-inverter and Optimizing Control System Using Finite Gradient Descent Method. *Proceedings of International Aegean Conference on Electrical Machines & Power Electronics, International Conference on Optimization of Electrical & Electronic Equipment & International Symposium on Advanced Electromechanical Motion Systems*, Side, Turkey, 287-292.
- Meneses, D., Blaabjerg, F., Garcia, O., & Cobos, J.A. (2013) Review and Comparison of Step-Up Transformerless Topologies for Photovoltaic AC-Module Application. *IEEE Transaction on Power Electronics*, 28(6), 2649-2663.
- Minjie, C., Khurram, K.F., & David, J.P. (2015) A Multilevel Energy Buffer and Voltage Modulator for Grid-Interfaced Microinverters. *IEEE Transactions on Power Electronics*, 30(3), 1203-1219.
- Nanakos, A.C., Tatakis, E.C., & Papanikolaou, N.P. (2012) A Weighted-Efficiency-Oriented Design Methodology of Flyback Inverter for AC Photovoltaic Modules. *IEEE Transaction on Power Electronics*, 27(7), 3221- 3233.
- Ognjen, G., Phuong, H.N., Wil, L.K., & Tadeusz, U. (2015) Microinverter Curtailment Strategy for Increasing Photovoltaic Penetration in Low-Voltage Networks. *IEEE Transactions on Sustainable Energy*, 6(2), 369-379.
- Pradeep, S., Priyabrata, S., & Somnath, M. (2015) Modeling and Control of Grid-Connected DC/AC Converters for Single-Phase Micro-inverter Application. *Proceedings of Annual IEEE India Conference*, New Delhi, India.
- Pradeepkumar, V.V.S., & Baylon, G.F. (2017) A Fault-Tolerant Single-Phase Grid-Connected Inverter Topology with Enhanced Reliability for Solar PV Applications. *IEEE Journal of Emerging and Selected Topics in Power Electronics*, 5(3), 1254-1262.
- Premkumar, M., Dhanasekar, N., Dhivakar, R., & Arunkumar, P. (2016) Comparison of MPPT Algorithms for PV Systems based DC – DC Converter. *Advances in Natural and Applied Sciences*, 17(9), 212-221.
- Premkumar, M., Jeevanantham, R., & Muthuvigneshkumar, S. (2014) Single Phase Module Integrated Converter Topology for Microgrid Network. *International Journal of Innovative Research in Electrical, Electronics, Instrumentation and Control Engineering*, 2(3), 1322-1325.
- Premkumar, M., Sumithira, T.R., & Sowmya, R. (2018) Implementation of Solar PV Based Microconverter with Optimal MPPT Control under Partial Shading Condition. *Interciencia Journal*, 43(2), 02-16.
- Premkumar, M., Sumithira, T.R., & Sowmya, R. (2018) Modelling and Implementation of Cascaded Multilevel Inverter as Solar PV Based Microinverter Using FPGA. *International Journal of Intelligent Engineering and Systems*, 11(2), 18-27.
- Sergio A.O., Leonardo P.S., Fernando M.O., & Fabio, R.D. (2017) A Feed-Forward DC-Bus Control Loop Applied to a Single-Phase Grid-Connected Photovoltaic System Operating with PSO-Based MPPT Technique and Active Power-Line Conditioning. *IET Renewable Energy Power Generation*, 11(1), 183-193.
- Shibin, Q., Christopher, B.B., & Robert, C.N.P.P. (2016) Enhancing Microinverter Energy Capture with Submodule Differential Power Processing. *IEEE Transactions on Power Electronics*, 31(5), 3575-3585.
- Srinivas, D., & Ramesh, J. (2014) Power Efficient Grid Connected Single Phase Rooftop PV System. *International Journal of Computational Science, Mathematics and Engineering*, 1(6), 231-238.
- Sukesh, N., Pahlevaninezhad, M., & Jain, P.K. (2014) Analysis and Implementation of a Single-Stage Flyback PV Microinverter with Soft Switching. *IEEE Transaction on Industrial Electronics*, 61(4), 1819,1833.
- Tarek, S., Mounir, B., Adel, G., & Ahmed, M. (2015) Microcontroller-based Inverter Topology Integrated in PV Systems. *COMPEL: The International Journal for Computation and Mathematics in Electrical and Electronic Engineering*, 34(1), 132-150.
- Thang, T.V., Thao, N.M., Jang, J.H., & Park, J.H. (2014) Analysis and Design of Grid-Connected Photovoltaic Systems with Multiple-Integrated Converters and a Pseudo-DC-Link Inverter. *IEEE Transaction on Industrial Electronics*, 61(7), 3377-3386.
- Tirthasarathi, L., & Vivek, A. (2016) Single Stage Multi-Port Flyback Type Solar PV Module Integrated Micro-Inverter with Battery Backup. *Proceedings of IEEE International Conference on Power Electronics, Drives and Energy Systems*, Trivandram, India.
- Umashankar, S., Akhil, M., & Kolhe, M. (2016) Control and Power Management of Photovoltaic Battery based Microgrid. *Proceedings of International Conference on Electrical Energy Systems*, Chennai, India.
- Vasav, G., & Parthasarathi, S. (2017) Design of Cuk Derived Transformerless Common Grounded PV Micro-inverter in CCM. *IEEE Transactions on Industrial Electronics*, 64(8), 6245-6254.
- Woo-Jun, C., Kyu-Tae, K., Yong-Won, C., Sung-Ho L., & Bong-Hwan, K. (2015) Evaluation and Analysis of Transformerless Photovoltaic Inverter Topology for Efficiency Improvement and Reduction of Leakage Current. *IET Power Electronics*, 8(2), 255-267.
- Woo-Jun, C., Yong-Won, C., Jung-Min, K., & Bong-Hwan, K. (2015) High Efficient Micro-Inverter with Soft-Switching Step-Up Converter and Single-Switch-Modulation Inverter. *IEEE Transactions on Industrial Electronics*, 62(6), 3516-3523.
- Yashi, S., Ikhlq, H., Bhim, S., & Sukumar, M. (2017) Single Phase Solar Grid-Interfaced System with Active Filtering using Adaptive Linear Combiner Filter-based Control Scheme. *IET Generation, Transmission & Distribution*, 11(8), 1976-1984.
- Yoash, L., & Robert, W.E. (2016) High Weighted Efficiency in Single Phase Solar Inverters by a Variable Frequency Peak Current Controller. *IEEE Transactions on Power Electronics*, 31(1), 258-269.
- Yoshiya, O., Koji, O., & Jun-ichi, I. (2015) A Single-Phase Current-Source PV Inverter with Power Decoupling

- Capability using an Active Buffer. *IEEE Transactions on Industry Applications*, 51(1), 531-538
- Yue, Z., Zhiliang, Z., & Gang, Y. (2015) A Novel Control Method for Photovoltaic Grid connected Microinverters to Achieve High Efficiency in Light Load. *Proceedings of 9th International Conference on Power Electronics-ECCE Asia*, Convention Center, Seoul, Korea, 2826-2831.
- Zhang, J., Huang, X., Wu, X., & Qian, Z. (2010) A High Efficiency Flyback Converter with New Active Clamp Technique. *IEEE Transaction on Power Electronics*, 25(7), 1775–1785.
- Zhang, Z., He, X.F., & Liu, Y.F. (2013) An Optimal Control Method for Photovoltaic Grid-Tied-Interleaved Flyback Micro-Inverters to Achieve High Efficiency in Wide Load Range. *IEEE Transaction on Power Electronics*, 28(11), 5074–5087.