



Contents list available at IJRED website , ISSN : 2252-4940

Int. Journal of Renewable Energy Development (IJRED)

Journal homepage: www.ijred.com

Design and Economic Analysis of a Photovoltaic System: A Case Study

C.O.C. Oko*, E.O. Diemuodeke, N.F. Omunakwe, and E. Nnamdi

Department of Mechanical Engineering, Faculty of Engineering, University of Port Harcourt, PMB 5323, Port Harcourt, NIGERIA

Article history:

Received July 22, 2012
 Received in revised form August 8, 2012
 Accepted August 15, 2012
 Available online

ABSTRACT: This paper presents the design analysis of a photovoltaic (PV) system to power the CAD/CAM Laboratory at the Department of Mechanical Engineering, University of Port Harcourt. Life cycle cost and break-even point analyses are also carried out to assess the economic viability of the system. The unit cost of electricity for the designed PV system is high compared to the current unit cost of the municipally supplied electricity, but will be competitive with lowering cost of PV system components and favourable government policies on renewable energy. The approach and data provided are useful for designing solar systems in the area. The automated MS Excel spreadsheet developed could be used for the design and economic analyses of PV system in any other geographical region once the input data are sorted. Since about 90% of businesses in Nigeria currently own diesel generators, it is expected that future work should be devoted to the optimum combination of PV-Battery-Diesel system in electricity generation for optimum economic benefits to the country.

Keywords: photovoltaic system design, renewable energy technology, solar energy economics

1. Introduction

Many research works on the utilization of renewable energy resources such as solar energy for electricity generation are ongoing in most regions of the world. This is as a result of the uncertainties surrounding the global oil and gas supplies and prices, and the adverse environmental impact of fossil fuel exploitation. The situation is even compounded in Nigeria, where electricity supply is grossly inadequate and unreliable. Public and private organisations and some individuals supplement the electricity provided by the national electricity grid with one that is independently supplied using their own diesel generators. It is estimated that about 90% of businesses in Nigeria own diesel generators [1]. For the institutions of higher learning in Nigeria, students' laboratory experiment, workshop practice, automated design and simulation are constantly disrupted from the epileptic municipal electricity supply by the Power Holding Company of Nigeria (PHCN). PHCN is the statutory body charged with the sole generation and supply of electricity in Nigeria. The institutions mitigate this by depending

heavily on electricity supply from diesel engine generators. But it has been shown that small to large electricity power demands can be met by the photovoltaic (PV) power systems [2].

Kolhe et al employed a life-cycle cost (LCC) analysis of various mixes of PV and diesel generators for a school in India [3]. They concluded that a stand-alone PV system is the most viable option when the power needs for the school are minimal and that PV systems will become more competitive as their costs decline. Ajan et al explored the possibility of installing an off-grid system that mixes PV technology with a diesel generator for a school in the state of Sarawak in East Malaysia [4]. Their results provide a critical cost for PV technology below which it would be beneficial for the school to invest in a PV system. Nafeh designed a stand-alone PV system to supply electricity to a remote-area-household in Egypt [5]. The work studies a stand-alone photovoltaic (PV) system to provide the required electricity for a single residential household in Sinai Peninsula of Egypt. The complete design of the proposed system takes into consideration the site

*Corresponding Author: Tel: +2348035536916
 Email: chika.oko@uniport.edu.ng

radiation data and the electrical load data of a typical household in the considered site.

Markvart noted that on a reasonable sunny site of insolation $20 \text{ MJm}^{-2}\text{day}^{-1}$, power produced from solar energy conversion technologies, PV and solar thermal, is significantly cheaper over extended use than that from diesel generators [6]. Ojosu argued that PV energy systems have special role to play in Nigeria power production, because of its substantial solar energy resources with daily solar radiation average of between 4 and 6 $\text{kW/m}^2/\text{day}$ [7]. Augustine and Nnabuchi showed that Port Harcourt city, which is located at the latitude of $04^{\circ}40'N$ and longitude of $07^{\circ}10'E$, has adequate sunshine for PV and solar thermal technologies [8].

Therefore, the purpose of this paper is to conduct a design and life cycle cost analysis, and simulation study of PV systems for the locality, and specifically, to develop one for the CAD/CAM laboratory at the Department of Mechanical Engineering, University of Port Harcourt, Port Harcourt, Nigeria, which is situated at a latitude of $04^{\circ}40'N$ and longitude of $07^{\circ}10'E$.

2. Design and Economic Analysis

The PV system development mainly entails the design and life cycle analyses of the system. These are now considered in the following sub-sections.

2.1 System Description

The Photovoltaic (PV) system is composed of a variety of components in addition to the photovoltaic modules, a balance-of-system that wired together to

form the entire fully functional system capable of supplying electric power; and these system elements are:

- PV cells, represent the fundamental power conversion units. They are made from semiconductors and convert sunlight to electricity. To increase the power output of PV cells, they are connected together to form larger units called modules. Modules, in turn, are connected in parallel and series to form a larger unit called panel.
- A storage medium (battery bank), stores the electrical energy produced by the PV cells, and makes the energy available at night or on dark days (days of autonomy or no-sun-days).
- A voltage regulator (or charge/discharge controller), reverses current and prevents battery from getting overcharged and overdischarged.
- An inverter, converts a low DC-voltage into usable AC-voltage; it may be a stand-alone installation or grid-connected installation.
- AC and DC loads, appliances and devices, which consume the power generated by the PV system.

Figure 1 shows the configuration of the stand-alone PV system with all the functional components.

2.2 Design Analysis

The PV system analysis entails system sizing, which is the process of estimating the required voltage and current rating for each component of the PV system to meet the electrical demand of the facility.

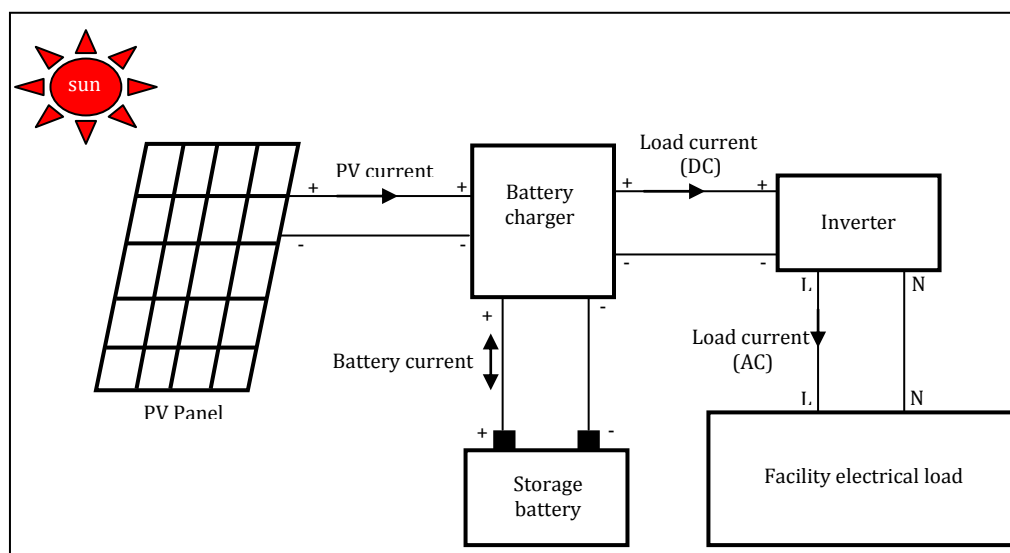

Fig. 1 Configuration of the Stand-Alone PV System

The daily energy demand, E_L (kWh/day), from the solar panel is given as [9]:

$$E_L = E_S / \eta_{overall} = \dot{W}_f H / \eta_{overall} \quad (1)$$

where E_S (kWh/day) is the estimated daily energy demand; $\eta_{overall}$ (-) is the overall system efficiency, which is the product of component efficiencies; W_f (kW) is the power rating of the facility; and H (h/day) is the number of hours the facility is in use per day.

The overall system efficiency is given as:

$$\eta_{overall} = \eta_{PV} \eta_B \eta_{INV} \quad (2)$$

where η_{PV} (-) is the PV module efficiency; η_B (-) is the battery efficiency; and η_{INV} (-) is the inverter efficiency.

The PV floor area, A_{PV} (m²), can be calculated by the following equation [10]:

$$A_{PV} = \frac{E_L}{I_{ave} T_{CF}} \quad (3)$$

where I_{ave} (kWh/m²/day) is the average daily energy (solar isolation) input over the year and T_{CF} (-) is the temperature correction factor.

The PV peak power, W_{PVP} (kWp), at peak solar isolation (PSI-kWp/m²) is given as [11]:

$$\dot{W}_{PVP} = A_{PV} \times PSI \times \eta_{PV} \quad (4)$$

The total system direct current, $I_{DC,sym}$ [Ah], needed can be calculated as follows [9]:

$$I_{DC,sym} = \frac{\dot{W}_{PVP}}{V_{DC,bus}} \quad (5)$$

where $V_{DC,bus}$ (V) is the DC bus voltage.

Modules are connected in series and parallel according to the system usage as follows:

- i. The number of PV module in series, N_{ms} (-), is obtained as:

$$N_{ms} = \frac{V_{DC,bus}}{V_{DC,mod}} \quad (6a)$$

where $V_{DC,mod}$ (V) is the PV module rated voltage

- ii. The string number of modules in parallel, N_{mp} (-) (each containing N_{ms}), is given as:

$$N_{mp} = \frac{I_{DC,sym}}{I_{DC,mod}} \quad (6b)$$

where $I_{DC,mod}$ (A) is the module rated current.

Therefore, the total number of modules that make up the panel is given as

$$N_m = N_{ms} N_{mp} \quad (7)$$

According to Oko and Nnamchi the optimal tilt angle, s^* (°), for a south facing fixed flat plate collector for the geographical location under consideration is given as [12]:

$$s^* = 2.9489 + 1.4050\phi - 0.0190\phi^2, \text{ for } 4.858 < \phi < 13.017 \text{ [}^\circ\text{]} \quad (8)$$

where ϕ [°] is the latitude of the location.

The storage capacity, S_{BC} (kWh), of the battery can be estimated according to the following relation [13, 14]:

$$S_{BC} = \frac{N_c E_s}{DOD \times \eta_B} \quad (9)$$

where N_c (day) is the largest number of continuous cloudy days of the location and DOD (-) is the maximum permissible depth of discharge of the battery.

If the dc bus voltage, $V_{DC,bus}$ is known, then one can present the storage capacity in Ampere-hour, S'_{BC} (Ah), as:

$$S'_{BC} = \frac{1000 S_{BC}}{V_{DC,bus}} \quad (10)$$

The total number of batteries, N_B (-), is obtained as:

$$N_B = \frac{S'_{BC}}{S'_{1,BC}} \quad (11)$$

where S'_{1BC} (Ah) is the capacity of one of the batteries selected for the system.

With the knowledge of the number of batteries, the connection of the battery bank can then be easily obtained. The number of batteries in series, N_{Bs} (-), is given as:

$$N_{Bs} = \frac{V_{DC,bus}}{V_{DC,1B}} \quad (12)$$

where $V_{DC,1B}$ (V) is the voltage rating of one of the batteries selected for the system.

The number of batteries in parallel, N_{Bp} (-), in string of N_{Bp} is given as:

$$N_{Bp} = \frac{N_B}{N_{Bs}} \quad (13)$$

Once the sizing of the battery bank is known, one proceeds to the sizing of the voltage regulator. A good

voltage regulator must be able to withstand the maximum current produced by the panel as well as the maximum load current. Sizing of the voltage regulator can be obtained by multiplying short circuit current of the modules connected in parallel by a safety factor, SF (-). The result is the rated current of the voltage regulator, I_{VR} (A), which is given as:

$$I_{VR} = N_{mp} I_{SC} \times SF \quad (14)$$

The power requirement of the inverter, W_{INV} (kW), is given as:

$$\dot{W}_{INV} = 1.25 P_{fd} \quad (15)$$

where P_{fd} (kW) is the power demand of the facility.

2.3 Life Cycle Cost Analysis

The life cycle cost (LCC) of an item consists of the total cost of acquiring and operating the item over its lifetime, expressed as the present worth [10]. The costs of a stand-alone PV system include: acquisition costs, operating costs, maintenance costs and replacement costs. Although the initial cost of the PV system is relatively high, the replacement costs, mainly for the storage batteries, and maintenance costs are relatively low, and there are no fuel costs [6].

The LCC for a PV system can be expressed as:

$$LCC = \sum_{q=1}^6 C_q; q \in \{1,2,3,4,5,6\} \equiv \{PV, B, VR, INV, INST, O \& M\} \quad (16)$$

where C_q (\$) is the present worth of a component and PV, B, VR, INT, INST and O&M stand for PV panel, battery, voltage regulator, inverter, installation and operation and maintenance, respectively.

The present worth of the batteries is given as:

$$C_B = C_{B0} + \sum_{k=1}^j C_{B0} \left(\frac{1+d}{1+i} \right)^{kn} \quad (17)$$

where i (%) is the interest rate; d (%) is the inflation rate; C_{B0} (\$) is the initial cost of the batteries; j (-) is the number of replacements; n is the life span of the battery, usually 5 years [5] and N (yr) is the life span of the PV system, usually 20 years [15].

The present worth of the operation and maintenance cost, $C_{O\&M}$ [\$], is expressed as:

$$C_{O\&M} = C_{O\&M/y} \left(\frac{1+i}{1+d} \right) \frac{1 - \left(\frac{1+d}{1+i} \right)^N}{1 - \left(\frac{1+d}{1+i} \right)} \quad (18)$$

where $C_{O\&M/y}$ (\$) is the operation and maintenance cost per year.

The annualized LCC (ALCC) of the PV system in term of the present day money can be expressed as:

$$ALCC = LCC \times \frac{1 - \left(\frac{1+d}{1+i} \right)}{\left(\frac{1+d}{1+i} \right)^N} \quad (19)$$

Therefore, the unit electrical cost, UEC (\$/kWh), is calculated from:

$$UEC = \frac{ALCC}{366 E_s} \quad (20)$$

Another parameter for measuring economic merit of a PV system is the break-even point (BEP) or the payback time (PBT), in years. The BEP is the number of years of it takes to recover an investment's initial cost, which is calculated as follows [16]:

$$BEP = \frac{LCC}{Q_{AP} \times UEC_{MC}} \quad (21)$$

$$\text{where } Q_{AP} = E_s \times 366 \times 24 \quad (22)$$

and Q_{AP} (kWh/year) is the annual energy production and UEC_{MC} (\$/kWh) is the cost of the conventional municipal electricity supply.

3. Input Data for Design and Economic Analyses

The input data for the design and economic analyses of the PV system under study are now presented in the following subsections.

3.1 Meteorological Data

The facility to be powered by the PV system is located at Choba Park campus of the University of Port Harcourt, Nigeria, which has a geographical position of latitude and longitude of 04°40'N and 07°10'E, respectively, with an average solar insolation and sunshine hours of 3.75 (kWh/m²/day) and 4.25 (h), respectively [17].

3.2 Facility Energy Demand

The power requirement of the CAD/CAM laboratory under consideration is estimated from the summation of power rating of the appliances in the facility, Table 1. Thus, the power rating of the facility is approximated to 10 kW, to account for future upgrade of the facility.

Table 1
Power Rating of the CAD/CAM Facility

S/No	Appliance	Quantity	Unit Power [kW/Unit]	Total Power [kW]
1	Laptop	5	0.025	0.125
2	Desktop Computer	10	0.350	3.500
3	Printer	1	1.230	1.230
4	Scanners	4	0.040	0.160
5	Fluorescent light	12	0.040	0.480
6	Television	1	0.140	0.140
7	Ceiling fan	8	0.075	0.600
8	Air Conditioner	4	0.750	3.000
Grand Total				9.235

3.3 Design and Economic Data

The PV system design and economic analyses are based on the input data in Table 2. The costs of the PV components are based on Abd El-Shafy [10]. The inflation and interest rates in Nigeria are 9.40 and 9.25%, respectively [18].

Table 2
Input Data for the Design and Economic Analysis

S/No	Item	Symbol	Units	Value		
1	Power rating of facility	W_f	kW	10.00		
2	Average hours of operation of the facility per day	H	h	9.00		
3	Average solar energy input	I_{av}	kWh/m ² /day	3.75		
4	Continuous cloudy days	N_c	day	4		
5	PV module efficiency	η_{PV}	-	0.12		
6	Battery efficiency	η_B	-	0.90		
7	Inverter efficiency	η_{INV}	-	0.90		
8	Temperature correction factor	T_{CF}	-	0.97		
Selected PV Module Standard Test Data (DB F80)						
9	Peak Solar Isolation	PSI	kW/m ²	1.00		
10	Maximum power	W_{PV}	kW	0.08		
11	Maximum voltage	$V_{DC,mod}$	V	17.50		
12	Short circuit current	I_{SC}	A	5.03		
13	DC bus voltage	$V_{DC,bus}$	V	24.00		
Selected Battery (Vision 6FM250D)						
14	Battery capacity	$S'_{1,BC}$	Ah	250		
15	Voltage	$V_{DC,1B}$	V	12.00		
16	Depth of discharge	DOD	-	0.80		
17	Safety factor	SF	-	1.25		
Cost Estimate for the PV Components						
Component:	PV	Battery	Charger	Inverter	Installation	M&O/year
Cost (in US Dollars):	5/ W_p	1.705/Ah	5.89/A	0.831/W	10% of PV	2% of PV

4. Results and Discussion

The output data and key parameter simulation for the design and economic analyses of the PV system under study are now presented in the following subsections.

4.1 Design and Economic Data

The computations were carried out, based on the input data in Tables 1 and 2, in a customized and elegant MS Excel spreadsheet for the design and economic analysis of PV system, on the basis of Equations (1) through (20). The design parameters are tabulated in Table 3, from where the cost of materials for the PV system is estimated in Table 4. This work adopted the overall system efficiency presented in Abd El-Shafy [10] and the PV peak power is based on the adopted available PV module in the Nigerian market. The life span of the system is taken as twenty (20) years [15], which is used to compute the LCC, the annualize life cycle cost (ALCC) and the unit electrical cost (UEC), Table 5.

Table 3

Design Parameters

S/No	Item	Symbol	Units	Value
1	Estimated daily energy demand	E_s	kWh/day	90
2	Overall system efficiency	$\eta_{overall}$	-	0.097
3	Required daily energy input	E_L	kWh/day	856
4	PV floor area	A_{PV}	m ²	235.10
5	PV peak power	W_{PVP}	kWp	28.21
6	Number of PV module required	N_m	-	354
7	Number of PV modules in series	N_{ms}	-	3
8	Number of PV module in parallel	N_{mp}	-	118
9	Storage capacity of battery in kWh	S_{BC}	kWh	461.75
10	Storage capacity of battery in Ampere-Hour	S'_{BC}	Ah	20000.00
11	Number of batteries	N_B	-	78
12	Number of batteries in series	N_{Bs}	-	2
13	Number of batteries in parallel	N_{Bp}	-	39
14	Rated current of voltage regulator	I_{VR}	A	1800.00
15	Power requirement of inverter	W_{INV}	kW	12.00

Table 4

Priced Bill of Engineering Materials

S/No	Item	Quantity	Unit Cost [US\$]	Total Cost [US\$]
1	PV Module	28210.00 W_p	5	141050.00
2	Battery	20000.00 Ah	1.705	35000.00
3	Charger	1800.00 A	5.890	10602.00
4	Inverter	12000 W	0.831	9972.00
5	Installation/contingencies		10% of PV	14105.00
Grand Total PV system cost				210729.00

Table 5

Economic Parameters

S/No	Item	Symbol	Present Worth (US\$)
1	PV Module	C_{PV}	141050.00
2	Battery	C_B	137814.91
3	Charger	C_{VR}	9521.83
4	Inverter	C_{INV}	9972.00
5	Installation	C_{INST}	14105.00
6	Operation and Maintenance	$C_{O\&M}$	57240.49
7	Life Cycle Cost (LCC)	LCC	369321.98
8	Annualized LCC (ALCC)	ALCC	18226.39
9	Unit Electrical Cost (UEC) per kWh	UEC	0.60
10	Break Even Time	BEP	10 years

One observes from Table 5 for the LCC analysis that the minimum unit electrical cost (UEC) per kWh of the designed system is 18.92% less than the value (0.74 US\$/kWh) Abd El-Shafy obtained for Abu Rudies city of Sinai Peninsula, Egypt [10]. This low UEC is attributed to the more favorable economic index in Egypt, inflation rate of 3% and interest rate of 10%, as against 9.40%

and 9.25%, respectively, for Nigeria. If this present work is based on the Egyptian economic index one obtains for the UEC per kWh a value of \$0.84, which is 13.51% higher than the one considered by Abd El-Shafy for the Egyptian site [10]. This increase is attributed to the higher insolation of 6.62 kWh/m²/day for the Egyptian site as against 3.75 kWh/m²/day for the

location of the facility considered in this work. Therefore, the UEC per kWh of a PV system is a strong function of the meteorological data and the prevailing economic index.

Also, from Table 5, the break-even point of the PV systems is ten (10) years, which means that the PV systems will pay for itself well before the warranted life

of the entire system is reached, allowing one to generates free electricity for the remaining ten (10) years of the useful live of the designed system. It is expected that municipal electricity cost will increase by 5% annually; once this is taken into account, the break-even point is only 6 - 7 years for PV systems that will be installed in the year 2020 as shown in Figure 2.

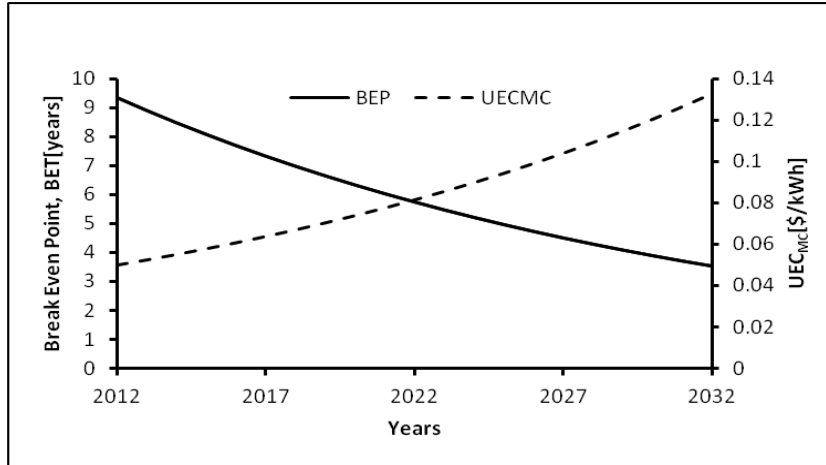

Fig 2. Economic Sensitivity of PV System with UEC_{Mc}

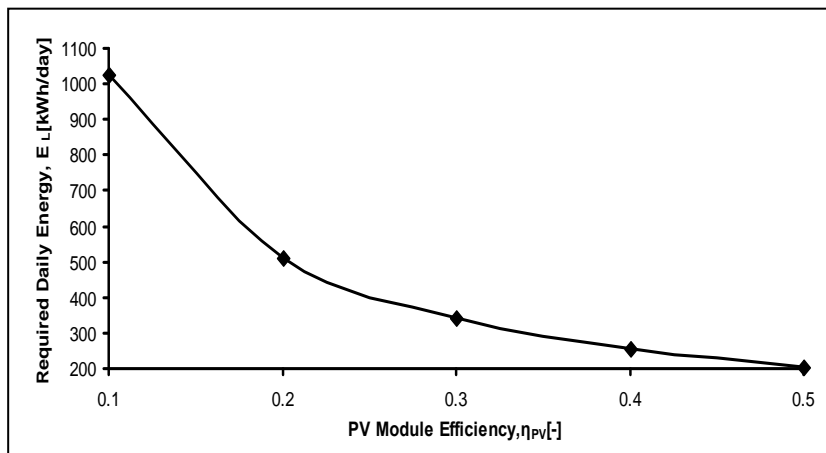

Fig 3. Daily Energy Demand vs PV Module Efficiency

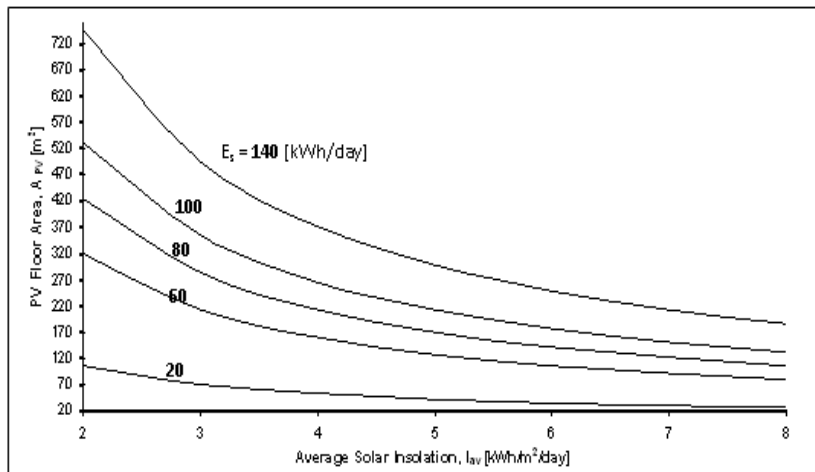

Fig 4. PV Floor Area as a function of the Daily Estimated Energy Demand, E_s, and Average Insolation, I_{av}, with the Temperature Correction Factor,

$$T_{CF} = 0.97$$

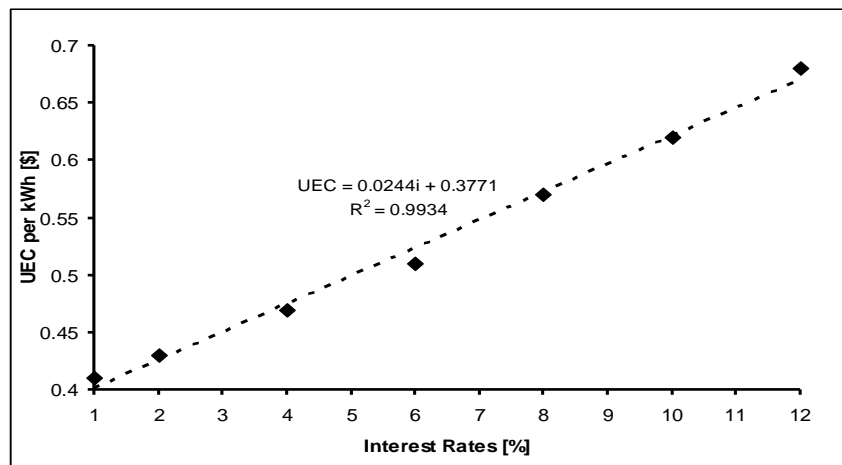

Fig 5. Unit Electrical Cost per kWh vs Interest Rates

Presently, there are no energy policies in Nigeria, which encourage the utilization of renewable energy, as it is done in most developed countries. But there are strong indications the Nigerian government will soon give tax waiver for imported PV system components. If this is achieved one expects that the BEP would be reduced drastically as a result of subsequent LCC reduction.

4.2 Simulations on Key Parameters

It is interesting to see, graphically, based on the PV system under consideration, the relationships between some design and economic parameters such as the PV efficiency and the required daily energy, the floor area, the average insolation and daily estimated energy demand, the UEC, and the interest and inflation rates.

Figure 3 shows the variation of the daily energy requirement of the PV system with its efficiency; the daily energy requirement of the PV system is decreasing with increasing PV system efficiency. This is because high PV efficiency would definitely culminate into high energy generation. Therefore, intensive research is required to produce PV modules with high energy conversion efficiency to make PV system compete favourably with other energy technologies.

Figure 4 shows that the PV floor area of the system, at constant temperature correction factor of 0.97[-], decreases as the estimated daily energy demand, E_s , and the average insolation, I_{av} , decreases and increases, respectively. This is expected because high solar insolation means abundant solar energy for electricity generation, thus, low PV floor area for the facility electrical energy demand.

As Figure 5 shows, the UEC per kWh of the PV system increases with increasing interest rate, at constant inflation rate. Thus, an appreciable reduction in the interest rate, and keeping inflation rate constant,

will encourage a wider application of the PV systems in the area. It is possible to predict the UEC of PV systems in climatic zone with Figure 5, as the prevailing interest rate moves.

5. Conclusion

A procedure for design and economic analyses of a stand alone PV system, embedded in a customized and elegant MS Excel spreadsheet, has been presented, and used for a facility located in Port Harcourt, Nigeria, at latitude 04°40'N and longitude 07°10'E. The automated MS Excel spreadsheet could be used for the design and economic analyses of PV systems in any other geographical region once the input data are sorted. The PV system for the facility studied is considered as the most promising energy technology due to its high reliability, sustainability and safety. The unit electricity cost (UEC) for the designed PV system is \$0.60/kWh, which is in no way comparable to the current UEC of \$0.05/kWh for the municipal electricity supply in the region. However, this price will drop to an appreciable value if the unit cost of PV system components and the prevailing interest rate drop appreciably. The break even point of the PV systems is ten (10) years, which means that the PV systems will pay for itself well before the warranted life of the panels is reached and allowing one to generate free electricity for the remaining ten (10) years. It is expected that the annual municipal electricity cost will increase by 5%; once this is taken into account the break even point or the payback time becomes only 6 - 7 years for PV systems that will be installed in the year 2020. Intensive research is, therefore, required to produce PV modules that can compete with other energy technologies. Although there are no currently existing policies, in Nigeria, to encourage utilization of renewable energy as it is done

in most developed countries, there are strong indications that Nigerian government will soon adopt energy policies on green and sustainable energy technology that will favour PV system utilization. The expected government energy policies include tax exemptions or holidays and low interest rate on equipment and capital for projects on photovoltaic systems. It worth noting that electricity supply in Nigeria is grossly inadequate and unreliable; that about 90% of businesses in Nigeria own diesel generators. Therefore, future work should focus on the optimum combination of PV-Battery-Diesel system in electricity generation for optimum economic benefits to Nigeria.

References

- [1] Energy Sector Management Assistance Program (2005) Nigeria: Expanding Access to Rural Infrastructure Issues and Options for Rural Electrification, Water Supply and Telecommunications, International Bank for Reconstruction and Development, World Bank, Washington D.C.
- [2] Angelis-Dimakis A, Biberacher M, Dominguez J, Fiorese G, Gadocha S, Gnansounou E, Guariso G, Kartalidis A, Panichelli L, Pinedo I, and Robba M (2011) Methods and tools to evaluate the availability of renewable energy sources. *J. Renewable and Sust. Energy Reviews* Vol.15: 1182-1200.
- [3] Kolhe M, Kolhe S, and Joshi JC (2002) Economic Viability of Stand-alone Solar Photovoltaic System in Comparison with Diesel-powered System for India. *J. Energy Economics*, 24 (2): 155-165.
- [4] Ajan CW, Ahmed SS, Ahmad HBTF, and Mohd Zin AAB (2003) On the policy of photovoltaic and diesel generation mix for an off-grid site: East Malaysian perspectives. *J. Solar Energy*, 74: 453-467.
- [5] Nafeh AA (2009) Design and Economic Analysis of a stand-alone PV system to electrify a remote area household in Egypt. *Open Renewable Energy Journal*, 2: 33-37.
- [6] Markvart T (2000) *Solar Electricity*, Wiley, London.
- [7] Ojusu JO (1990) The Iso-radiation Map for Nigeria. *J. Solar and Wind Tech.*, 7 (5): 563-575.
- [8] Augustine C and Nnabuchi MN (2009) Relationship between global solar radiation and sunshine hours for Calabar, Port Harcourt and Enugu, Nigeria. *Int. Journal of Physical Sci.*, 4 (4): 182-188.
- [9] Assad A (2010) A Stand-Alone Photovoltaic System, Case Study: A Residence in Gaza. *J. of Applied Sciences in Environmental Sanitation*, 5 (1): 81-91.
- [10] Abd El-Shafy AN (2009) Design and Economic Analysis of a Stand-Alone PV System to Electrify a Remote Area Household in Egypt. *The Open Ren. Energy Journal*, 2: 33-37.
- [11] Alamsyah TMI, Sopian K, Shahrir A (2003) In Technoeconomics Analysis of a Photovoltaic System to Provide Electricity for a Household in Malaysia. *Proceedings in International Symposium on Renewable Energy: Environment Protection & Energy Solution for Sustainable Development*, Kuala Lumpur, 387-396.
- [12] Oko COC and Ogoloma OB (2011) Generation of Typical Meteorological Year for Port Harcourt Zone. *Journal of Engineering Science and Technology*, 6(2): 204-214.
- [13] Wenham SR, Green MA, Watt ME (1994) *Applied Photovoltaics*, Centre for Photovoltaic Devices and Systems, Sydney.
- [14] Mahmoud MM, Ibrik IH (2006) Techno-economic Feasibility of Energy Supply to Remote Villages in Palestine by PV-Systems, Diesel Generator and Electric Grid. *Renewable Sustainable Energy Rev.*, 10: 128-138.
- [15] Messenger R, and Ventre J (2000) *Photovoltaic Systems Engineering*, CRC Press LLC: Boca Raton, Florida.
- [16] Al-Smairan M, Al-Adamat R, and Al-Nhoud O (2012) Techno-Economic Feasibility of Energy Supply of Remote Dump Site in Jordan Badia by Photovoltaic Systems, Diesel Generators and Electrical Grid. *Research Journal of Applied Sciences, Engineering and Technology*, Vol. 4(9): 1073-1081.
- [17] Oko COC and Nnamchi SN (2012) Optimum Collector Tilt Angles for Low Latitudes. *The Open Renewable Energy Journal*, 5: 7-14.
- [18] Trading Economics (2011) *World Economic Index*, www.tradingeconomics.com/nigeria [accessed 06/11/11].