

# Essential Oil Extraction of Fennel Seed (*Foeniculum vulgare*) Using Steam Distillation

Astrilia Damayanti<sup>#1</sup> and Eko Setyawan<sup>\*2</sup>

<sup>#</sup> Chemical Engineering Program – Semarang State University, Indonesia

<sup>1</sup>[astriliad@staff.unnes.ac.id](mailto:astriliad@staff.unnes.ac.id)

<sup>\*</sup> Graduate Chemical Engineering Program - Semarang State University, Indonesia

<sup>2</sup>[ockernaffello@yahoo.co.id](mailto:ockernaffello@yahoo.co.id)

**Abstract** — Indonesia is a potential country in developing essential oils which is each part of the plants produce essential oils such as leaf, seed, fruit, and root. One of the potential plants is fennel. Fennel oil distillation used fennel seed from Cepogo District, Boyolali Regency. The characteristics of the seed are; the color is black and the length is 0,2 centimeters. The condition operation to extract of the fennel seed are 1 atm and 7,5 hours. The calculation of the time started when the first fennel oil dropped into the decanter. It finished when the fennel oil was not dropped anymore. The color is bright and muddy. The last process is add 1% (m/m) Na<sub>2</sub>SO<sub>4</sub> anhydrous into fennel oil to absorp remain water in it. The distillation process produce fennel oil 102,125 grams. Sample of fennel oil tested which are density test, solubility on 90% alcohol, GC-MS test, and AAS test. The result shows that fennel oil from the fennel seed is 2,0425%. The tested samples contain the brightest and the muddies sample. The density of 0,9500 and 0,949 g/cc respectively that is not fulfill to the Food Chemical Codex (FCC). Samples solubility in 90% alcohol (1:3) is fulfill to the the Food Chemical Codex (FCC). Three main components of the brightest sample are anethole (47,51%), estragole (22,41%), and  $\alpha$ -fensone (21,92%) while the muddiest sample's components are anethole (52,38%), estragole (21,37%), and  $\alpha$ -fensone (15,74%). The AAS test shows that fennel oil contains 65,1473 ppm which does not fulfill the Indonesian National Standards of patchouli and clove leaf oil.

**Keywords**— essential oil, extraction, fennel seed, steam distillation

## I. INTRODUCTION

Indonesia is a potential country in developing essential oils in the world because it has several of essential oil producing plants. The term of "essential oil" or "etheric oil" means a volatile oil and is obtained from plants by steam distillation method [2]. Essential oil is the basic material of producing perfumes and cosmetics. The essential oil which is derived from spices, such as; pepper oil, cinnamon oil, ginger oil, clove oil, coriander oil, is commonly used as a food and beverages flavor [5]. One of the potential plants is fennel.

*Foeniculum vulgare* Miller belongs to fennel plant taxonomic species [5]. The fennel seed is distilled to produce fennel oil which is useful in pharmaceutical industry as a cough medicine, antiseptic, and laxative [6] and as an addictive substance in various types of cuisine, bakery, confectionery, pharmaceuticals, and cosmetics [3]. The Physico-chemical characteristics of fennel oil can be seen in Table 1.

Table 1. Physico-chemical characteristics of fennel oil

Characteristics	Value
Color	Clear, pale yellow
Specific gravity, at 25 ° C	0.978 to 0.988
optical rotation	(-2) -10
Refractive index at 25 ° C	1.55
Solubility in alcohol 90%	perfectly soluble 1:3

Sources: Food Chemical Codex [8]

The main component of fennel oil is anethole and anise oil. Fennel oil contains of 50-60% anethole [12], while anise oil contains for about 80-90% anethole [9]. The fennel oil quality is determined by the amount of anethole content. The fennel oil has a better quality if it has higher content of anethole [9].

Research of fennel essential oil in Indonesia which is from Boyolali, Cipanas, and Bintang stated that they have different oil content of fennel. The highest of fennel seed oil content is from Bintang, that is 6.15%. The highest oil production of Fennel is 4.21% while the content of anethole is 26.17% [1].

The retrieval process of essential oils are; supercritical extraction, pressing, extraction with solvent extraction, extraction with fat, and distillation (distillation). Weaknesses of supercritical extraction process is the price of equipment which is very expensive due to high requirement of the operating pressure [7].

The steam distillation process (direct) is a steam distillation using steam. It flows through a circular pipe which is located below the porous material and the vapor moves upward through the material that is located on the top sieve [5].

The purpose of this research is to determine the yield and characteristics (density and solubility in alcohol) in accordance with the Food Chemical Codex (FCC) and the chemical components of fennel seed oil using the distillation method.

## II. MATERIALS AND METHODS

The distillation of fennel seeds use raw materials from the Cepogo District, Boyolali, Indonesia. It use 5 kg of material with characteristic black beans, 0.2 mm length, and has a distinctive flavour.

Five kilograms of fennel seeds are introduced into the kettle distilled (distillation equipment can be observed in the Figure 1). The boiler is heated up using the stove as a supplier of the steam and the operation pressure is 1 atmosphere; distillation time is 7.5 hours, which is calculated since the first

distillate drips in the separator tank; the oil is taken apart every hour; distillation was stopped when the distillate obtained in the separator tank doesn't contain fennel seed oil anymore

The Distillate from the separator tank is transferred for separating funnel in the oil phase of the aqueous phase. After that, the fennel seed oil is taken apart from the water, then it continues the analysis of the yield calculation, the density proof and the test of solubility in alcohol.

Fennel oil component test is carried out by means of gas chromatography and mass (GC-MS), and testing the metal content of iron (Fe) fennel oil, by means of Atomic Absorption Spectroscopy (AAS).

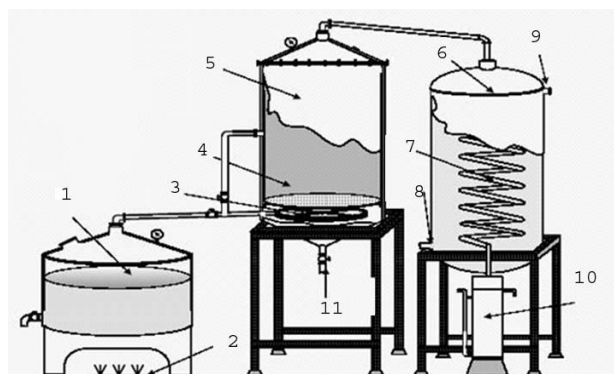

Figure 1. Distillation Equipment

Caption:

- 1. Boiler
- 2. Fire
- 3. Steam distributor
- 4. Boiler materials with a perforated sieve
- 5. Distillation kettle
- 6. Condenser
- 7. Coil
- 8. Water in
- 9. Water out
- 10. Separator tank

The yield of fennel seed oil is the ratio between the mass of fennel seed essential oil distillation and the distilled fennel seed mass, expressed in % by weight. The presence of water and glycerin in the oil samples is very important because it indicates its degree of purity. If it does not meet any quality requirement, the sale value of the oil will be much cheaper [4].

The aim of testing the solubility of the fennel seed oil in alcohol is to determine the purity of essential oils from the distillation of anise, which is done by putting 2 ml samples of fennel oil in a measuring cup, then adding 90% alcohol and finally the mixture is shaken to get completely dissolved. The addition of alcohol is made little by little to produce a clear solution until the ratio of fennel oil: alcohol = 1:3.

GC-MS test is performed to determine the chemical constituents in the fennel seed oil and AAS test is to determine the metal content in the fennel seeds oil distillates.

### III. RESULTS AND DISCUSSION

Fennel seed oil produced in the refining process varies in a color between the nodes to light brown .This color is divided into 6 according to the distillery. In the first three hours after the distillate dripping with oil, the colors that it produces tend to get darker, although the colour of the oil

increases its clarity at the end of distillation. This is because the steam is not yet stable at the beginning of oil refining, fact which affects in the color of the distillate. The color difference is due to distillate oil in the metal content. The boiler is made of iron. Fennel seed oil produced from the steam distillation has 105 grams with a flavor distinctive of fennel oil. Next, 40 grams sample plus 1% (m / m) anhydrous Na<sub>2</sub>SO<sub>4</sub> to absorb the remaining water in the fennel seed oil. The mass of pure anise oil samples after the addition of anhydrous Na<sub>2</sub>SO<sub>4</sub> is 38.1732 grams of clear yellow oil. This means that fennel seed oil distillates can still contain water at 4.567%, so the mass of total fennel seed oil distillates has 100.2025 grams.

These results stated that yield of fennel seed oil is 2.0425%, therefore lower than in the already existing research. This is because the base material and fractionation in a distillation kettle affects to oil content. Steam distillation of anise from fennel oil-producing of Eastern Europe is at 2.5 to 4.0% [3], while the results of Anwar's research [9] suggested that in fennel seed oil from Boyolali (Central Java) the steam distillation is from 2.66 to 3.23%.

The density test of fennel seed oil performed on samples that have the most striking difference in color, which is the most turbid and the clearest, results of the essential oil of fennel seeds is shown in Table 2.

Table 2. Density test of fennel seed oil

Samples of fennel seed oil	Density (g/mL)			Average
	The first test	The second test	The third test	
1. the most turbid	0,9499	0,9499	0,9512	0,9500
2. the clearest	0,9494	0,9487	0,9489	0,9490

The resulting density of the two samples do not meet the requirements of fennel seed oil on Food Chemical Codex (FCC). This is due to the FCC is an international standard and every fennel oil from different countries also has different densities.

The fennel seed oil in alcohol into the two samples (the most turbid and the clearest) gets dissolved completely with a ratio of 1:3, therefore the fennel seed oil distillates fulfills FCC standards.

GC-MS test results with the most turbid samples (Figure 2) and the clearest samples (Figure 3) shows that the component is detected according to the literature. Steam distillation of fennel seeds original from Eastern Europe contains the components:  $\alpha$ -pinene, kamfen,  $\alpha$ -felladren, dipenten, anethole, fenson, estragol, foenikulin, anisaldehyda, and anisat acid [3], while the results of Anwar's research [9] showed that the steam distillation of anise Boyolali (Central Java) produces the oil composition of fennel with the fenson main compound: (20%), estragol (22.31%), and anethole (45.35% ).

Table 3 shows that there are nine components contained in the fennel seeds oil. The three largest components in this sample are: anethole (47.51%), estragol (22.41%), and  $\alpha$ -fenson (21.92%). Table 4 shows that the content of fennel seed oil has a total of 11 components which the three main are anethole (52.38%), estragol (21.37%), and  $\alpha$ -fenson

(15.74% ). From these two tables can be seen that the most clear sample have more components than the sample with the most turbid and have a higher level of anethole. This is caused by differences in time to get the two samples. The most turbid sample with the color obtained after a time of distillation of 240 minutes, while the clearest sample distillation is reached after 360 minutes. Th difference, and the number of sample components with the clearest sample is what causes the levels of major components than in the most turbid samples with color.

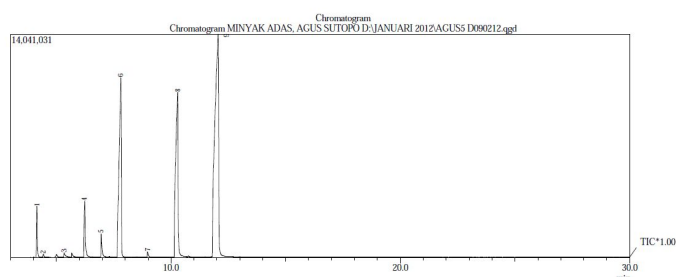

Figure 2. Chromatograms with the most turbid sample

Table 3. GC-MS test results with the most turbid sample

Peak	Retention time	Area (%)	Component
1	4,151	2,45	$\alpha$ -pinene
2	4,383	0,17	champene
3	5,300	0,26	$\beta$ -myrcene
4	6,192	3,73	limonene
5	6,925	1,23	$\delta$ -carene
6	7,650	21,92	$\alpha$ -fenchone
7	8,942	0,33	champor
8	10,117	22,41	estragole
9	11,775	47,51	anethole

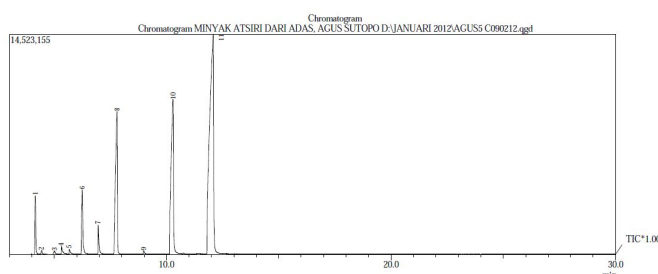

Figure 3. Chromatograms with the clearest sample

Table 4. GC-MS test results with the clearest samples

Peak	Retention time	Area (%)	Component
1	4,155	2,97	$\alpha$ -pinene
2	4,433	0,21	champene
3	5,005	0,26	$\beta$ -pinene
4	5,320	0,45	$\beta$ -myrcene
5	5,668	0,30	thujene
6	6,244	4,56	limonene
7	6,957	1,53	$\delta$ -carene
8	7,790	15,74	$\alpha$ -fenchone
9	8,950	0,22	champor
10	10,117	21,37	estragole
11	11,783	52,38	anethole

In general, the two samples that were analyzed using GC-MS test produce more chemical components and anethole levels than in literature. In the most turbid samples with color and the clearest sample contain 47.51% and 52.38 anethole %

whereas in the mentioned literature contain 40.33% anethole. This suggests that the essential oil of fennel seed research results have relatively better quality than those referred the literature.

AAS test results showed that the samples contain metallic Fe, measured levels of FE done in triplo in mixed samples of the clearest and the most turbid with results of measurements of 65.618 ppm, 64.912 ppm and 64.912 ppm. The average of these measurements is 65.1473 ppm. This Fe content exceeds the threshold set by the Indonesian National Standards (SNI). SNI patchouli and clove leaf oil requires to be 25 ppm the maximum Fe content in essential oil [10,11]. This suggests that the fennel seed oil research must be done so its quality fulfill Indonesian National Standards of purification.

#### IV. CONCLUSIONS

Yield of fennel seed steam distillation is 2.0041%. The color density of the sample with the most turbid and the clearest color in a row is 0.9500 and 0.949 g / mL. Solubility in the alcohol test showed that the samples get dissolved completely in alcohol 90% with a ratio 1:3. The three main components of fennel seed oil with the coloured most turbid samples are: anethole (47.51%), estragol (22.41%), and  $\alpha$ -fenson (21.92%), while in the color of the purest samples containing anethole component are (52.38%), estragol (21.37%), and  $\alpha$ -fenson (15.74%). Fennel seed oil contain 65.1473 ppm of Fe.

#### ACKNOWLEDGMENT

Thanks to the laboratory of chemical engineering that served distillation equipment for this research, and also for student who help me so this research can run well.

#### REFERENCES

- [1] Fahmi, Zaki Ismail. 2011. *Perkembangan Teknologi Budidaya Adas*. ditjenbun.deptan.go.id/bbp2tptsur/images/.../budidaya%20adas.pdf. Accessed : 5<sup>th</sup> January 2012
- [2] Guenther, E. 1987. *Essential Oils*, Diterjemahkan oleh Ketaren S. Minyak Atsiri. Jilid I. Jakarta: Universitas Indonesia Press.
- [3] \_\_\_\_\_. 1990. *The Essential Oils*, Diterjemahkan oleh Ketaren S. Minyak Atsiri. Jilid IV B. Jakarta: Penerbit Universitas Indonesia Press.
- [4] Hernani dan Tri Marwati. 2006. *Peningkatan Mutu Minyak Atsiri Melalui Proses Pemurnian*. <http://Hernani dan Tri Marwati Minyak Atsiri Indonesia.htm>. Accessed : 5<sup>th</sup> January 2012.
- [5] Ketaren, S. 1985. *Pengantar Teknologi Minyak Atsiri*. Jakarta: Balai Pustaka.
- [6] Ma'mun dan Shinta Suhirman. 2011. *Karakteristik Minyak Atsiri Potensial*. [balitro.litbang.deptan.go.id/ind/images/stories/edsus/.../5mamun.pdf](http://balitro.litbang.deptan.go.id/ind/images/stories/edsus/.../5mamun.pdf). Accessed : 5<sup>th</sup> January 2012
- [7] Ramadhan, A.E. dan Haries Aprival Phaza. 2010. Pengaruh Konsentrasi Etanol, Suhu dan Jumlah Stage pada Ekstraksi Oleoresin Jahe (*Zingiber Officinale* Rosc) Secara Batch. Skripsi. Universitas Diponegoro. Semarang
- [8] Rusli, M.S. 2010. *Sukses Memproduksi Minyak Atsiri*. Jakarta: AgroMedia Pustaka.
- [9] Sastrohamidjojo, H. 2004. *Kimia Minyak Atsiri*. Yogyakarta: Gadjah Mada University Press
- [10] SNI 06-2385-2006 minyak daun nilam.pdf. [http://sisni.bsn.go.id/index.php?/sni\\_main/sni/detail\\_sni/7400](http://sisni.bsn.go.id/index.php?/sni_main/sni/detail_sni/7400) Accessed : 5<sup>th</sup> January 2012
- [11] SNI 06-2387-2006 minyak daun cengkeh.pdf. [http://sisni.bsn.go.id/index.php?/sni\\_main/sni/detail\\_sni/7590](http://sisni.bsn.go.id/index.php?/sni_main/sni/detail_sni/7590) Accessed : 5<sup>th</sup> January 2012
- [12] Tjiptosupomo, G. 1988. *Taksonomi Tumbuhan*. Cetakan ke-3. Yogyakarta: Gadjah Mada University Press.