

Hidden Environmental Impact of COVID-19 Vaccination: Waste Management, Treatment, and Global Warming Potential

Iva Yenis Septiariva¹, Ariyanti Sarwono², I Wayan Koko Suryawan^{2*}

¹ Civil Engineering Study Program, Faculty of Engineering, Universitas Sebelas Maret, Jl. Ir. Sutami No.36, Surakarta-Jawa Tengah 57126, Indonesia

² Department of Environmental Engineering, Faculty of Infrastructure Planning, Universitas Pertamina Jl. Teuku Nyak Arief, Jakarta 12220, Indonesia

*corresponding author: iwynkokosuryawan1@gmail.com

Info Artikel: Diterima 17 Februari 2022 ; Direvisi 11 April 2022 ; Disetujui 11 April 2022

Tersedia online : 9 Mei 2022 ; Diterbitkan secara teratur : Juni 2022

Cara sitasi (Vancouver): Septiariva IY, Sarwono A, Suryawan IWK. Hidden Environmental Impact of COVID-19 Vaccination: Waste Management, Treatment, and Global Warming Potential. Jurnal Kesehatan Lingkungan Indonesia [Online]. 2022 Jun;21(2):137-143. <https://doi.org/10.14710/jkli.21.2.137-143>.

ABSTRAK

Latar belakang: Indonesia, negara terpadat keempat di dunia, muncul sebagai episentrum Covid-19 di Asia pada pertengahan tahun 2021. Lonjakan kasus COVID19 mendorong negara untuk menargetkan 1 juta vaksinasi Covid-19 per hari.

Metode: Penelitian ini menggunakan data kualitatif dari tinjauan pustaka sebelumnya kemudian diolah menggunakan perhitungan yang sesuai dengan metode pengelolaan limbah vaksin.

Hasil: Meskipun peluncuran vaksinasi besar-besaran, dampaknya terhadap lingkungan masih dipertanyakan. Tidak hanya pembuangan limbah medis yang tidak tepat tetap menjadi tantangan sejak wabah pandemi pada tahun 2020, tetapi vaksinasi memperburuk keadaan. Selain limbah padat, konsumsi listrik dan emisi polutan dari zat pendingin mungkin berkontribusi terhadap jejak karbon yang tinggi.

Simpulan: Makalah ini menyoroti pentingnya pengelolaan limbah selama Covid-19 dan konsekuensi tak terduga pada penyimpanan dan penanganan vaksin untuk pengambilan keputusan peluncuran vaksinasi lebih lanjut.

Kata kunci: Vaksin; Covid-19; Pengelolaan Limbah; Jejak Karbon

ABSTRACT

Background: Indonesia, the world's fourth most populous country, emerged as Asia's Covid-19 epicenters in the mid of 2021. The surge in COVID19 cases drives the nation to aim for 1 million Covid-19 vaccinations per day.

Method: This study uses qualitatively and quantitatively data from previous literature reviews and then processed using calculations that are in accordance with the vaccine waste management method.

Result: Despite massive vaccination rollout, the impact on the environment is still in question. Not only has improper medical waste disposal remained a challenge since the pandemic breakout in 2020, but the vaccination worsened the circumstances. In addition to solid waste, the electricity consumption and pollutant emissions of the refrigerants might contribute to a high carbon footprint.

Conclusion: This paper highlights the importance of waste management during Covid-19 and unforeseen consequences on vaccine storage and handling for decision making of further vaccination rollouts.

Keywords: Vaccines; Covid-19; Waste Management; Carbon Footprint

INTRODUCTION

In January 2021, Indonesia's confirmed COVID-19 infections since the pandemic exceeded 1 million. Indonesia's Health Ministry announced that new daily infections rose by 13,094 to bring the country's total to 1,012,350, the most in Southeast Asia with the total number of deaths reaching 28,468 (1)⁽¹⁾. In order to curtail nation, the spread of the COVID-19 virus, massive vaccination efforts have been authorized. Vaccination, by definition, is a process that stimulates a person's immune system to produce immunity to a specific disease, protecting the person from the disease. The administration of vaccines, commonly through needle injection, will prevent one from illness. Group immunity is when most of the community is protected/immune to certain diseases. It has an indirect impact, that is, protecting vulnerable groups of people who are not the target of vaccination. This condition can only be achieved with high and equal vaccination coverage. As the world's fourth most populous country, the Indonesian government aims to inoculate a total of 208,265,720 people by the end of the year 2021⁽²⁾.

One of the Government's efforts to control the Covid-19 pandemic is to carry out mass vaccinations nationally, the target is to target 181.5 million Indonesians until 2022^(3,4). The aim is to reduce the number of deaths and positive cases of Covid-19, prevent and protect public health, achieve herd immunity, maintain productivity and social and economic impact, and protect and strengthen the overall health system. The strategy is based on clusters, adding vaccinators, increasing vaccination

staff by using public facilities, strengthening the management of vaccination in the regions, and increasing the number of vaccines in Indonesia. Implementation of the Covid-19 vaccination to improve the quality of medical waste. Currently, there are still many health care facilities that do not treat their medical waste optimally⁽⁵⁻⁹⁾. Medical waste during the Covid-19 pandemic does not only come from health facilities⁽¹⁰⁻¹³⁾. However, also from community waste in the form of masks, surgical gloves, and various personal protective equipment for Covid-19 sufferers who are self-isolating. So far, medical waste has been included in household waste, which is handled as household waste is generally carried out, and this can endanger the environment due to the infectious nature of the waste. The purpose of this study is to determine the environmental impact caused by vaccination activities and the management efforts that can be carried out in Indonesia.

MATERIAL AND METHOD

This research was conducted qualitatively and quantitatively with a literature review. The study of the existing condition is carried out by taking the latest information about the problems that occur so that an appropriate system can be built in the management of vaccine waste. Data collection techniques are also taken from relevant data that supports this study. The data is then processed using the method used to determine the generation of vaccine waste, the amount of vaccine waste composition, the calorific value of vaccine waste, and the vaccine waste management system.

$$\text{Waste Composition (w/w \%)} = \frac{\text{Waste Generation (kg)} - \text{Waste component weight(kg)}}{\text{Waste Generation (kg)}} \quad (1)$$

$$\text{Potential for total calorific value (MJ)} = \text{Waste generation} \left(\frac{\text{kg}}{\text{day}} \right) \times \text{Calorific value waste component} \left(\frac{\text{MJ}}{\text{kg}} \right) \quad (2)$$

$$\text{The calorific value of the mixture of the waste (MJ/kg)} = \frac{\text{Waste Generation (kg)} - \text{Calorific value waste component (MJ/kg)}}{\text{Waste Generation (kg)}} \quad (3)$$

RESULT AND DISCUSSION

3.1. Existing Vaccination Waste Management

During the pandemic, domestic waste has soared predominantly due to masking waste from personal protective equipment (PPE)⁽¹⁴⁻¹⁶⁾. While vaccine prevents COVID-19 transmission, recent massive vaccine rollout creates paramount concern on vaccine waste, consequently, boosting medical waste volume. The above situation worsens Indonesia's waste issue. Improper waste disposal, categorized as

hazardous waste, a shorthand for hazardous and toxic wastes, was found in several areas in Indonesia. Medical waste such as PPE, injections, swabs, and rapid test kits, used for handling Covid-19, was deliberately dumped and put in sacks on the outskirts of Jalan Raya Sukatani, Sukaindah Village, Sukakarya, Bekasi Regency, West Java⁽¹⁷⁾. Another finding in the Punakawan Temporary Shelter, Jatinom Village, Blitar Regency, every day, hundreds of used medical masks adorn the piles of waste⁽¹⁸⁾. Piles of

medical waste from the antigen swab test were also found on the edge of the Simpang Bakauheni Toll Road, South Lampung where this waste was not packaged properly like an infectious waste⁽¹⁹⁾. In another case in Cipanas town, West Java, hundreds of vaccine bottles were abandoned arbitrarily into a temporary garbage dump as well as in the public waste disposal⁽²⁰⁾.

3.2. Vaccination Waste Thermochemical Treatment

Due to a shortage in waste processing facilities, Indonesia's government allows hospitals to burn their waste without license amidst emergencies. The COVID-19 vaccination program in Indonesia potentially generates 7,578,800 kg of medical waste as conveyed by the Director of Performance Assessment of Hazardous Waste and Non-Hazardous waste management from the Ministry of Environment and Forestry (KLHK)⁽²¹⁾. Some of the medical waste comes from the vaccine packaging with a dosage of 2.5 ml and a weight of 10 grams per bottle, a syringe with 10 grams per pcs, a needle for

injection with a weight of 1 gram, and a cotton swab with a weight of 2 grams. As mentioned earlier, Indonesia's need for the COVID-19 vaccine to achieve herd immunity is approximately 426 million doses, on account of this, the estimated amount of waste produced can be seen in Table 1. While the composition of waste from vaccination activities (w/w) is depicted in Figure 1.

The approximate total waste generation resulting from overall vaccination is roughly 9605 tons, tabulated in Table 1. The waste must be thermally treated to destroy the pathogens present in the waste. Suryawan et al., states that vaccine bottles and needle waste are comprised of 100% of ash content⁽²⁴⁾. Meanwhile syringe and cotton are having an ash content of 69% and 65.3%, respectively^(23,24). Based on the calculation of the ash content of each component, the total value of produced ash as residual is 8005.7 tonnes with the assumption of destruction efficiency for the vaccine waste is merely about 83.9% from the total waste.

Table 1. Projections of the Waste Generation and Characteristics of Solid Waste Ash of Vaccine Components

Component	Weight Per Pcs	Projected Total Vaccine Dose	Total Waste Generation (Tons)	Ash Content (%)	Total Ash as Residual (ton)
Vaccine bottle	Volume 2.5 ml with a weight of 10 grams per bottle	426 million doses	4260	100% ¹⁾	3295.0
Syringe	10 gr		4260	69% ²⁾	2273.6
Needle	1 gr		426	100% ¹⁾	329.5
Cotton	2 gr		659	65.3% ³⁾	430.3
Total (ton)			9605	-	8055.7
Destruction Efficiency (%)			83.9		

¹⁾ (22); ²⁾ (23); ³⁾ (24)

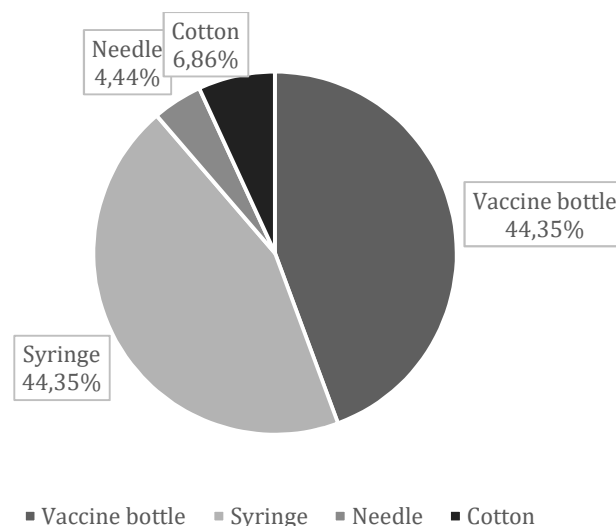

Figure 1. Composition of Solid Waste Medical Waste from Vaccination Activities

Ash from burning medical waste frequently contains heavy metals such as Pb, Zn, Cd, and Fe^(22,25-27). Accordingly, the total combustion product of 8005.7-tons must be stabilized/solidified (S/S) to bind

the toxic properties of the combustion ash. In previous research, the S/S processes can secure the toxic properties of ash from the combustion before disposal of non-hazardous to landfills^(22,28).

3.3. Global Warming Potential from Vaccination Waste Management

Apart from solid waste generation, vaccine storage can lead to unforeseen consequences to our environment particularly by increasing carbon footprint. Approved COVID-19 vaccines in Indonesia require specific storage conditions ranging from -75°C to 8°C. The use of refrigerants in the automatic vaccine distribution process requires electrical energy, installation, periodic maintenance, repairs, and ultimately generates a carbon footprint emission that is closely associated with greenhouse gases (GHG). GHG is often found in refrigerators, foam or aerosol cans, anesthetic activities, and semiconductor manufacturing⁽²⁹⁾. Total Equivalent Warming Impact (TEWI) storage of several types of vaccines used depends on the amount of electricity used. It can be seen from the research that has been done by Santos et al. the use of Pfizer-BioNTech vaccines tends to be higher⁽³⁰⁾ (Table 2). Given the storage of this vaccine must be at a temperature of -70 °C that the energy requirements are higher than other types of vaccines.

The massive use of refrigerants in the distribution of vaccines will subsequently contribute to a high carbon footprint. Though coolants use considerably low energy, these devices contain chemicals that can undergo a phase transition from a cold liquid to gas and back to liquid. During the process, this energy will release heat to the surroundings. The type of chemical, in many instances, used in refrigeration, is chlorofluorocarbons, better known as CFCs. The release of CFCs will lead to the depletion of the ozone layer in the atmosphere. Some alternatives can replace CFCs with two other groups of chemicals, i.e. hydrofluorocarbons (HFCs) and hydrochlorofluorocarbons (HCFCs). Unfortunately, both HFCs and HCFCs likely cause some issues to environments. The said compounds are unable to break down the ozone molecules and create a powerful greenhouse effect. Their capacity to enter the atmosphere can trigger global warming equivalent to thousands of times greater than carbon dioxide. In conclusion, it is pivotal to address the environmental issue for decision making in further vaccination rollout.

Table 2. Total Equivalent Warming Impact of Vaccine Used in Brazil and USA (30)

Vaccine	TEWI Total in Brazil (TON CO ₂ 10 year)	TEWI Total in USA (TON CO ₂ 10 year)
Moderna	367,416.47	1,511,546.87
CoronaVac (Sinovac)	166,512.35	632,423.06
AstraZeneca	166,512.35	632,423.06
Pfizer-BioNTech	1,452,355.09	5,806,106.98

With the rising energy need for vaccination, the distribution of vaccines is looking for opportunities to reduce costs and environmental impact without affecting quality. Investment in energy-efficient technology can make a significant contribution to the reduction of costs⁽³¹⁾. The steps that need to be taken by managers to increase electrical energy savings include the use of a variable frequency drive^(32,33) to regulate the electric motor driving the compressor in cold storage and air blast freezer when the load is not working. In addition, the use of a soft starter reduces the peak current at startup. The pattern of cold storage operations can be optimized by determining more effective product transfer procedures to reduce the opening and closing of cold storage doors.

3.4. Cradle to Grave Vaccination Waste Management

Vaccination waste in Indonesia is classified as hazardous waste whose management is regulated in Government Regulation Number 101 of 2014 concerning Management of Hazardous and Toxic Waste. Hazardous and Toxic Waste Management is carried out with principles and uses safe and environmentally friendly waste management methods. Special facilities are needed from the time the waste is generated (from the cradle) until it is destroyed (to grave) (Figure 2). Covid-19 medical waste needs to be taken seriously^(34,35). Research shows that the cause of Covid-19, the Severe Acute Respiratory Syndrome Coronavirus 2 (SARS-CoV-2), survives in certain temperature and humidity conditions. It can take several days for the virus to infect humans, depending on the type of surface material on which it lives. However, with standard disinfection processes using soap, disinfectant or heating the virus will be easy to inactivate or in other words not be contagious⁽³⁶⁾. Environmental conditions were found to be a factor in the spread of the virus, so it is necessary to pay extra attention to the themes and goals of sustainable development⁽³⁷⁾ for Indonesia.

Vaccine waste treatment including in the processing of health facilities can use an incinerator with a minimum temperature of 800°C. It must be admitted that no country is ready to face the Covid-19 outbreak, including Indonesia. The steps taken by the government in overcoming the Covid-19 medical waste capacity gap are still relatively high for big cities in Indonesia, where infectious waste treatment technology still depends on incinerators. For this reason, the government needs to create a healthy investment climate for medical waste processing and transportation services. One of the reasons for the low investment in this sector is complicated licensing.

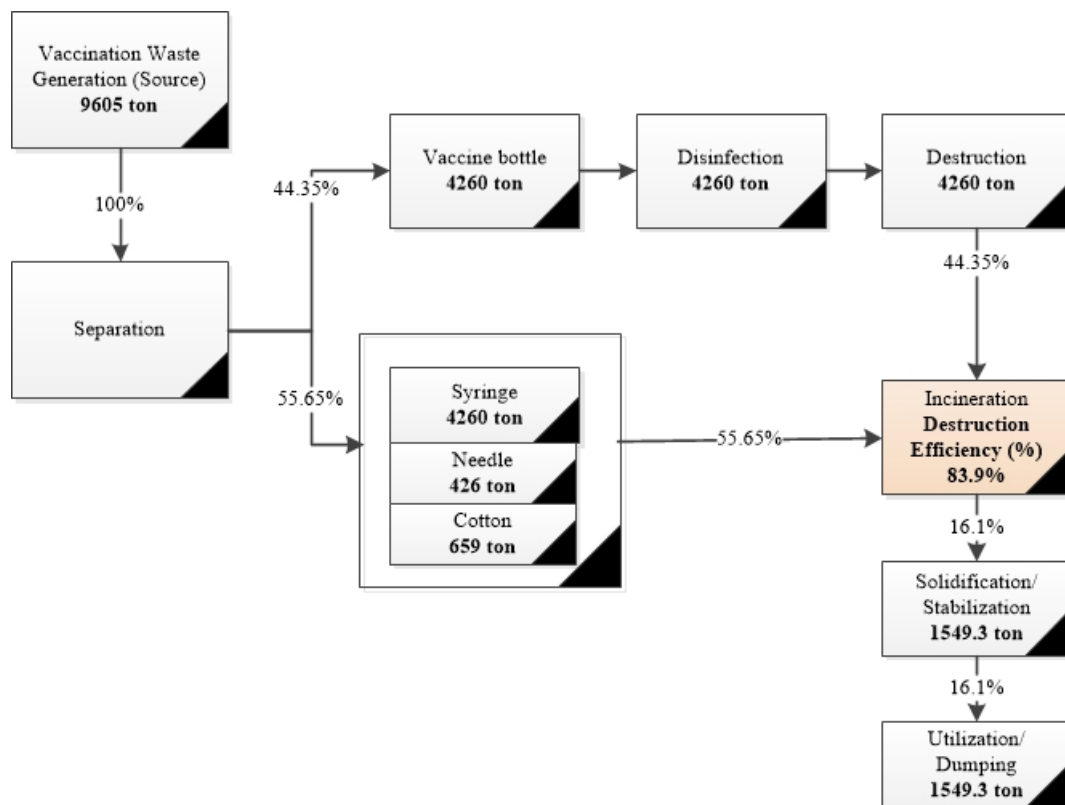

Figure 2. Schematic of Vaccine Waste Management Process from Cradle to Grave

CONCLUSIONS

With the surge of covid cases, the Indonesian government aims to vaccinate a total of 208,265,720 people by the end of the year 2021. Though vaccines prevent COVID-19 spreading massive vaccine rollout contributes to medical waste volume in addition to personal protective equipment. Improper waste disposal and lack of treatment facilities were still encountered in several areas in Indonesia. The approximate total waste generation resulting from overall vaccination is roughly 9605 tons and the total value of produced ash is as residual as 005.7 tonnes. A vaccine waste management approach from cradle to grave should be implemented to tackle such issues. In addition to solid waste, the energy consumption of vaccine storage and pollutant emissions of the refrigerants might contribute to a high carbon footprint. Therefore, it is crucial to address this subject such as vaccine selection and proper waste disposal and management to fully eliminate the environmental impact of vaccination.

REFERENCES

1. KARMINI I, TARIGAN E. Indonesia's confirmed coronavirus cases exceed 1 million [Internet]. 2021. Available from: <https://apnews.com/article/pandemics-jakarta-indonesia-coronavirus-pandemic-asia-5eca0484e70f8b702fa6d4ea1e9c2780>
2. Suryahadi A, Al Izzati R, Yumna A. The Impact of Covid-19 and Social Protection Programs on Poverty in Indonesia. *Bull Indones Econ Stud* [Internet]. 2021 Sep 2;57(3):267–96. Available from: <https://doi.org/10.1080/00074918.2021.2005519>
3. Sutomo S, Sagala S, Sutomo B, Liem W, Al Hamid H. Strengthening the strategic and operational response for reducing covid-19 transmission in Indonesia. *Kesmas*. 2021;16(1):3–10. <https://doi.org/10.21109/kesmas.v16i3.5225>
4. Sastramidjaja Y, Rosli AA. Tracking the Swelling COVID-19 Vaccine Chatter on TikTok in Indonesia. *Perspective*. 2021;(82):1–12.
5. Aung TS, Luan S, Xu Q. Application of multi-criteria-decision approach for the analysis of medical waste management systems in Myanmar. *J Clean Prod* [Internet]. 2019;222:733–45. Available from: <https://www.sciencedirect.com/science/article/pii/S0959652619307383>. <https://doi.org/10.1016/j.jclepro.2019.03.049>
6. Su G, Ong HC, Ibrahim S, Fattah IMR, Mofijur M, Chong CT. Valorisation of medical waste through pyrolysis for a cleaner environment: Progress and challenges. *Environ Pollut* [Internet]. 2021;279:116934. Available from: <https://www.sciencedirect.com/science/article/pii/S0269749121005169>. <https://doi.org/10.1016/j.envpol.2021.116934>
7. Irfai M, Arifin A, Kriswandana F, Thohari I. The Design of Medical Waste Treatment in

- Public Health Center (MWT-P) for Reducing Total Bacteria Count in Banjarbaru. *J Kesehat Lingkungan*. 2020;12(4):254. <https://doi.org/10.20473/jkl.v12i4.2020.254-261>
8. Mahendradhata Y, Andayani NLPE, Hasri ET, Arifi MD, Siahaan RGM, Solikha DA, et al. The Capacity of the Indonesian Healthcare System to Respond to COVID-19 [Internet]. Vol. 9, *Frontiers in Public Health*. 2021. p. 887. Available from: <https://www.frontiersin.org/article/10.3389/fpubh.2021.649819>. <https://doi.org/10.3389/fpubh.2021.649819>
 9. Wulansari A, Sudarno, Muhammad F. Medical waste management at community health center: a literature review. *E3S Web Conf* [Internet]. 2020;202. Available from: <https://doi.org/10.1051/e3sconf/202020206017>
 10. Sangkham S. Face mask and medical waste disposal during the novel COVID-19 pandemic in Asia. *Case Stud Chem Environ Eng*. 2020 Sep 1;2:100052. <https://doi.org/10.1016/j.cscee.2020.100052>
 11. Goswami M, Goswami PJ, Nautiyal S, Prakash S. Challenges and actions to the environmental management of Bio-Medical Waste during COVID-19 pandemic in India. *Heliyon* [Internet]. 2021;7(3):e06313. Available from: <https://www.sciencedirect.com/science/article/pii/S2405844021004187>. <https://doi.org/10.1016/j.heliyon.2021.e06313>
 12. Sari MM, Inoue T, Septiariva IY, Suryawan IWK, Kato S, Harryes RK, et al. Identification of Face Mask Waste Generation and Processing in Tourist Areas with Thermo-Chemical Process. *Arch Environ Prot*. 2022;
 13. Sari MM, Yosafaat M, Nastiti AK, Septiariva IY, Utomo FS, Putri CA, et al. Planning of Single-Used Mask Waste Containers as Personal Protective Equipment: A Case Study of Jakarta City Station. *Int J Public Heal Sci*. 2022;11.
 14. Cordova MR, Nurhati IS, Riani E, Nurhasanah, Iswari MY. Unprecedented plastic-made personal protective equipment (PPE) debris in river outlets into Jakarta Bay during COVID-19 pandemic. *Chemosphere*. 2021 Apr 1;268:129360. <https://doi.org/10.1016/j.chemosphere.2020.129360>
 15. Suryawan IWK, Sarwono A, Septiariva IY, Lee C-H. Evaluating Marine Debris Trends and the Potential of Incineration in the Context of the COVID-19 Pandemic in Southern Bali, Indonesia. *J Ilm Perikan dan Kelaut*. 2021;13(1). <https://doi.org/10.20473/jipk.v13i2.25164>
 16. Ruslinda Y, Aziz R, Putri FF. Analysis of Household Solid Waste Generation and Composition During The. *Indones J Environ Manag Sustain*. 2020;9.
 17. Adi N. *Polisi Selidiki Temuan Limbah Rapid Test di Pinggir Jalan Bekasi* [Internet]. 2020. Available from: <https://www.merdeka.com/peristiwa/polisi-selidiki-temuan-limbah-rapid-test-di-pinggir-jalan-bekasi.html>
 18. Edika I. *Alat Rapid Test dan Masker Medis Ditemukan di Tempat Sampah, Petugas Kebersihan Berisiko Covid-19* [Internet]. 2021. Available from: <https://www.kompas.tv/article/211264/alat-rapid-test-dan-masker-medis-ditemukan-di-tempat-sampah-petugas-kebersihan-berisiko-covid-19>
 19. Afandi A. *Duh, Limbah Medis Alat Swab Antigen Berceceran di Pinggir Tol Simpang Bakauheni* [Internet]. 2021. Available from: <https://lampung.inews.id/berita/duh-limbah-medis-alat-swab-antigen-berceceran-di-pinggir-tol-simpang-bakauheni>
 20. Selamet I. *Terlalu! Ratusan Limbah Botol Vaksin Dibuang Sembarangan ke TPS Cianjur* [Internet]. 2021. Available from: <https://news.detik.com/berita-jawa-barat/d-5199576/terlalu-ratusan-limbah-botol-vaksin-dibuang-sembarangan-ke-tps-cianjur>
 21. Sri Nurhayati Q. *VAKSINASI COVID-19 DAN PENANGANAN LIMBAHNYA*. Pus Penelit Badan Keahlian Sekr Jenderal DPR RI [Internet]. 2021;0(5):18–9. Available from: https://www.google.com/url?sa=t&rct=j&q=&esrc=s&source=web&cd=&ved=2ahUKEWiLhPet_ybDzAhUf7XMBHYFSDu8QFnoECCIQAQ&url=http%3A%2F%2Fberkas.dpr.go.id%2Fpuslit%2Ffiles%2Fisu_sepekan%2Fisu%2520Sepekan---III-P3DI-Februari-2021-189.pdf&usg=AOvVaw0dwq02lv-F4dERFklG
 22. Suryawan IWK, Prajati G, Afifah AS. *Bottom and fly ash treatment of medical waste incinerator from community health centres with solidification/stabilization*. *Explor Resour Process Des Sustain URBAN Dev Proc 5th Int Conf Eng Technol Ind Appl* 2018. 2019;2114(June):050023. <https://doi.org/10.1063/1.5112467>
 23. Pasek AD, Gultom KW, Suwono A. *Feasibility of recovering energy from municipal solid waste to generate electricity*. *J Eng Technol Sci*. 2013;45(3):241–56. <https://doi.org/10.5614/j.eng.technol.sci.2013.45.3.3>
 24. Adedokun OM, Akuma AH. *Maximizing Agricultural Residues: Nutritional Properties of Straw Mushroom on Maize Husk, Waste Cotton and Plantain Leaves*. *Nat Resour*. 2013;04(08):534–7. <https://doi.org/10.4236/nr.2013.48064>
 25. Akyıldız A, Köse ET, Yıldız A. *Compressive strength and heavy metal leaching of concrete containing medical waste incineration ash*. *Constr Build Mater*. 2017 May 1;138:326–32.

- <https://doi.org/10.1016/j.conbuildmat.2017.02.017>
26. Li Y-M, Wang C-F, Wang L-J, Huang T-Y, Zhou G-Z. Removal of heavy metals in medical waste incineration fly ash by Na₂EDTA combined with zero-valent iron and recycle of Na₂EDTA: A columnar experiment study. *J Air Waste Manage Assoc* [Internet]. 2020 Sep 1;70(9):904–14. Available from: <https://doi.org/10.1080/10962247.2020.1769767>
 27. Liu F, Liu H-Q, Wei G-X, Zhang R, Liu G-S, Zhou J-H, et al. Detoxification of medical waste incinerator fly ash through successive flotation. *Sep Sci Technol* [Internet]. 2019 Jan 2;54(1):163–72. Available from: <https://doi.org/10.1080/01496395.2018.1481091>
 28. Vavva C, Lymperopoulou T, Magoulas K, Voutsas E. Chemical Stabilization of Fly Ash from Medical Waste Incinerators. *Environ Process*. 2020;7(2):421–41. <https://doi.org/10.1007/s40710-020-00425-8>
 29. Penman J, Gytarsky M, Hiraishi T, Irving W, Krug T. 2006 IPCC - Guidelines for National Greenhouse Gas Inventories. Directrices para los Inventar Nac GEI [Internet]. 2006;12. Available from: <http://www.ipcc-nggip.iges.or.jp/public/2006gl/index.html>
 30. Santos AF, Gaspar PD, de Souza HJL. Refrigeration of COVID-19 vaccines: Ideal storage characteristics, energy efficiency and environmental impacts of various vaccine options. *Energies*. 2021;14(7). <https://doi.org/10.3390/en14071849>
 31. Wu H, Tassou SA, Karayiannis TG, Jouhara H. Analysis and simulation of continuous food frying processes. *Appl Therm Eng* [Internet]. 2013;53(2):332–9. Available from: <https://www.sciencedirect.com/science/article/pii/S1359431112002669>
 32. Gandhi K, K.L.Mokariya, Karvat D, Raval MK. Effect of PWM Inverter Used In VFD on Induction Motor Performance and Comparison with Direct on Line Start. *Int J Eng Res Technol*. 2014;3.
 33. Aditya T. Research to study Variable Frequency Drive and its Energy Savings. *Int J Sci Res*. 2013;2(6):2319–7064.
 34. Septiariva, Sarwono A, Suryawan IWK, Ramadan BS. Municipal Infectious Waste during COVID-19 Pandemic: Trends, Impacts, and Management. *Int J Public Heal Sci* [Internet]. 2022;11(2). Available from: <http://doi.org/10.11591/ijphs.v11i2.21292>
 35. Zhao H, Liu H, Wei G, Zhang N, Qiao H, Gong Y, et al. A review on emergency disposal and management of medical waste during the COVID-19 pandemic in China. *Sci Total Environ* [Internet]. 2022;810:152302. Available from: <https://www.sciencedirect.com/science/article/pii/S0048969721073782>. <https://doi.org/10.1016/j.scitotenv.2021.152302>
 36. Chin AWH, Chu JTS, Perera MRA, Hui KPY, Yen H-L, Chan MCW, et al. Stability of SARS-CoV-2 in different environmental conditions. *The Lancet Microbe* [Internet]. 2020;1(1):e10. Available from: [https://doi.org/10.1016/S2666-5247\(20\)30003-3](https://doi.org/10.1016/S2666-5247(20)30003-3)
 37. Rahimi NR, Fouladi-Fard R, Aali R, Shahryari A, Rezaali M, Ghafouri Y, et al. Bidirectional association between COVID-19 and the environment: A systematic review. *Environ Res* [Internet]. 2021;194:110692. Available from: <https://www.sciencedirect.com/science/article/pii/S0013935120315917>. <https://doi.org/10.1016/j.envres.2020.110692>



©2022. This open-access article is distributed under the terms and conditions of the Creative Commons Attribution-ShareAlike 4.0 International License.