



2301-9069 (e)
1829-8370 (p)

Kapal: Jurnal Ilmu Pengetahuan dan Teknologi Kelautan (Journal of Marine Science and Technology)

journal homepage : <http://ejournal.undip.ac.id/index.php/kapal>

Collision Analysis Of A Self Propelled Oil Barge (SPOB) Using Finite Element Method



Amalia Ika Wulandari^{1*)}, Rodlian Jamal Ikwani¹⁾, Suardi Suardi¹⁾, Ratna Septati Yani¹⁾, Andi Nadia Himaya²⁾, Alamsyah Alamsyah³⁾

¹⁾Naval Architecture Program, Kalimantan Institute of Technology, Balikpapan 76127, Indonesia

²⁾Department of Transportation and Environmental Systems Engineering, Hiroshima University, Japan

³⁾Naval Architecture Program, Kalimantan Institute of Technology, Balikpapan 76127, Indonesia

^{*)}Corresponding Author: amaliaikaw@lecturer.itk.ac.id

Article Info

Abstract

Keywords:

Collision;
Finite Element;
Ship;
SPOB;

Article history:

Received: 25/03/2022
Last revised: 15/07/2022
Accepted: 16/07/2022
Available online: 16/07/2022
Published: 16/07/2022

DOI:

<https://doi.org/10.14710/kapal.v19i2.45417>

Many ship accidents at sea cause oil spills that can pollute the sea especially ships carrying crude oil that experiences a collision, for example SPOB ship. SPOB is a ship that transports crude palm oil in Indonesia. Basically, the ship is collided with a jetty due to ocean waves hitting the hull as consequently the ship hull experienced a deformation. This research will be carried out on SPOB ships that experienced a collision with a jetty using two variations of the model, namely the jetty with fenders and without fenders with variation of speed. This study aims to determine the stress and deformation that occurs in the hull when experiencing a collision with a jetty. The method used in this study is a nonlinear method using Ansys. The results reveal that increasing speed of the ship is in line with stress and deformation values.

Copyright © 2022 KAPAL : Jurnal Ilmu Pengetahuan dan Teknologi Kelautan. This is an open access article under the CC BY-SA license (<https://creativecommons.org/licenses/by-sa/4.0/>).

1. Introduction

Many ship accidents occur at sea which cause fuel oil and lubricating oil spills to pollute the sea. This case often occurs in ships carrying crude oil or petroleum that have leaks due to collisions [1][2][3]. Ship collision will have a significant impact on the strength of the ship's structure related to ship safety [4][5][6]. According to data from the Lloyd Register, statistics on ship sinking are determined by collisions and shipwrecks [7][8].

The collision on the ship that occurs will cause deformation to the tearing of the hull which causes an oil spill. Most cases of ship accidents occur due to the collision of the ship with the pier which results in a large wave impact when the engine is off [9][10]. The occurrence of large waves that occur periodically will cause the ship's hull to split. A large blow from the waves would result in the bow of the ship being stuck in the jetty, while the stern would be washed ashore [11][12].

Basically, the ship's hull is deformed when the ship is going to rest on the jetty, which causes the hull to collide with the jetty repeatedly due to ocean waves hitting the hull. This makes the ship's hull vulnerable to damage [13][14]. A ship or vessel coming into contact with the seafloor or the side of a waterway while in operation is said to have "grounded" [2- 6]. On the other hand, unplanned occurrences like marine accidents can also result in grounding. Extreme weights from severe groundings put enormous strain on ship structures, leading to hull breaches, cargo spills, total vessel loss, and human casualties. In less serious cases, grounding might simply harm the outer hull locally. Current/water flow, darkness and reduced visibility, tide and sea states, visibility owing to fog and other obstacles, wind and weather conditions, depth of waterways, geometry of waterways, and density of traffic volume are some of the factors that might lead to grounding occurrences. the size of the vessel, the age of the vessel, the distribution of water depth, and the history of grounding occurrences; the kind of vessel Speed of vessel; organizational and human elements; terrorism, war, and piracy [15][16]. Indonesia has many SPOB ships which have not been studied widely, in this study an analysis was carried on a SPOB by modeling the ship and jetty by varying the speed of the ship.

Therefore, in the present study, the collision between the hull and the jetty using the finite element method is performed, this study aims to determine the damage that occurs to the hull when colliding with the jetty with fenders and without fenders at a certain speed variation [17][3]. Finally, the stress and deformation values on the SPOB 3500 DWT ship are obtained.

2. Methods

In general, the research stage is contained in the flow diagram shown in Fig. 1 and will be explained comprehensively step by step.

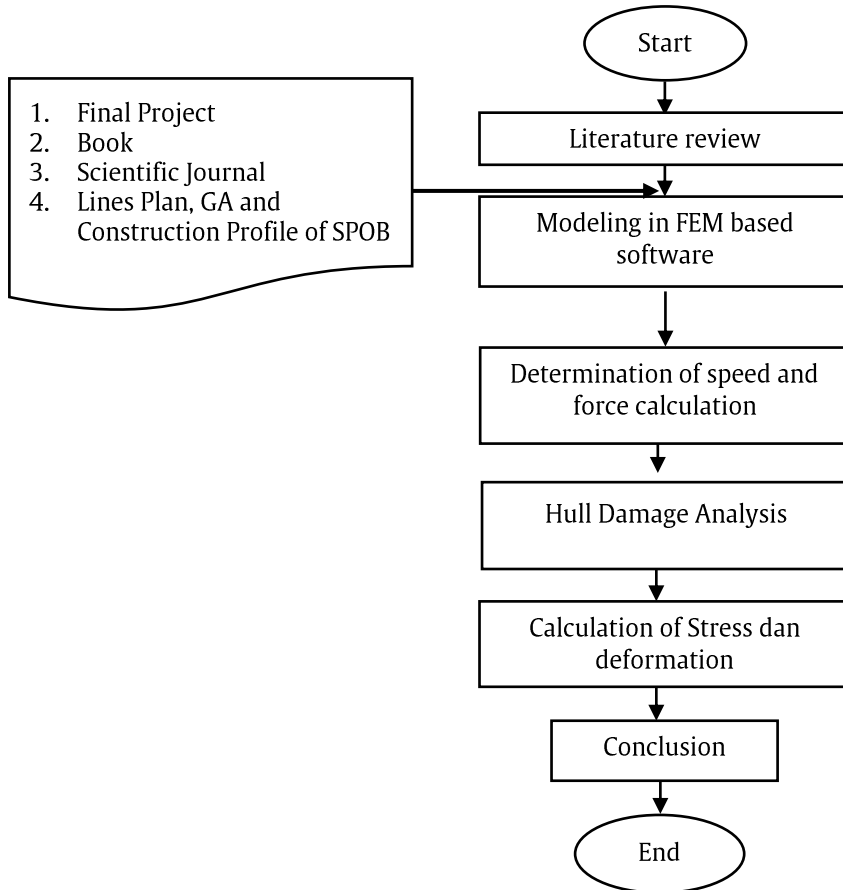
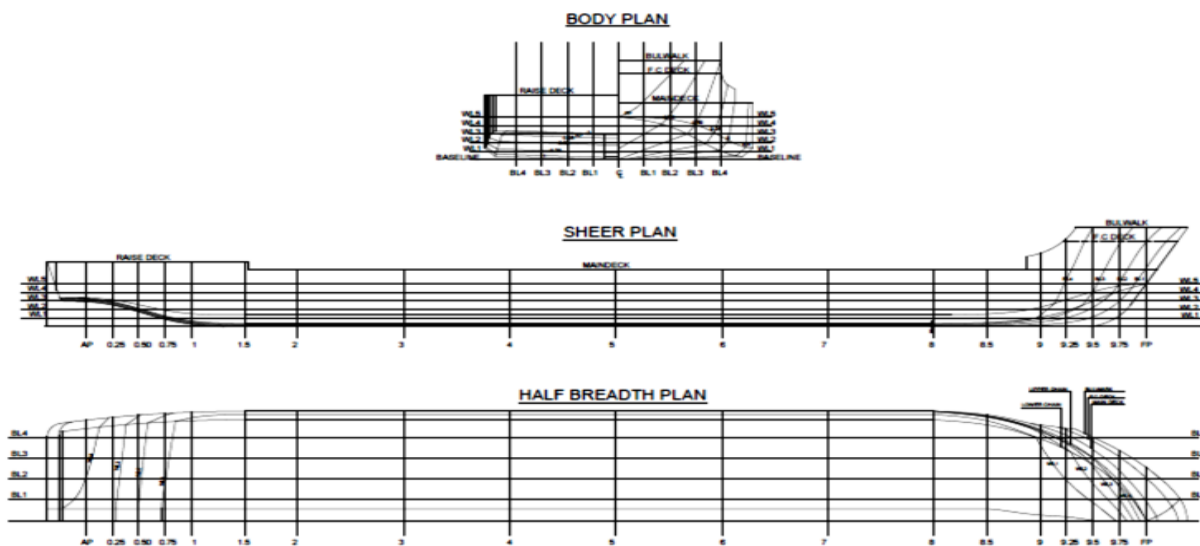
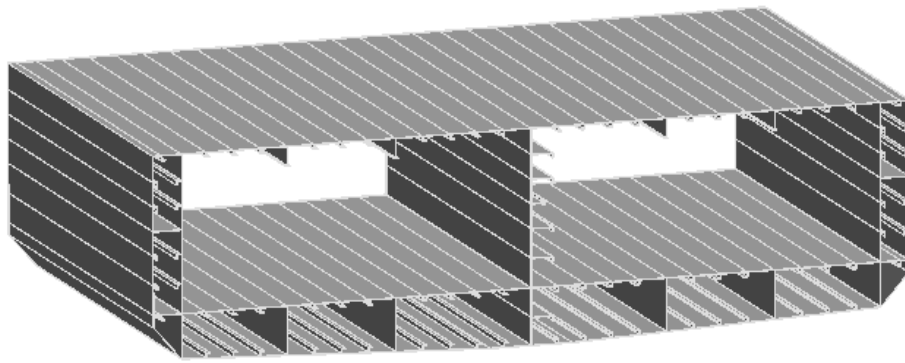

Figure 1. Research Flow Chart

Data processing of the Self Propelled Barge Oil (SPOB) 3500 DWT vessel is carried out by modeling the vessel, calculating stresses, and seeing the deformation value using finite element-based software, namely Ansys Explicit Dynamics.



(a)



(b)

Figure 2. a) Lines Plan GT b) SPOB model design

In jetty and fender modeling it's the same when drawing midship by using the software Ansys Explicit Dynamics Space claim shown in Fig. 2.

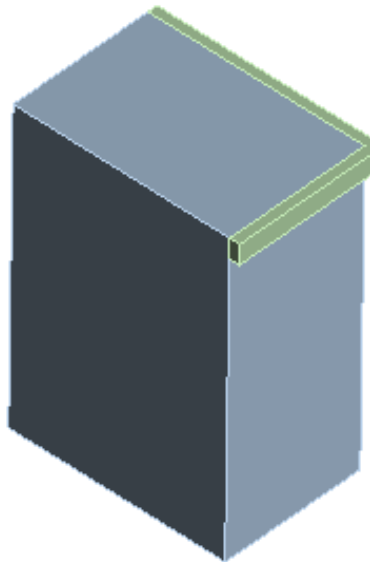

Figure 3. Fender Model

Collecting data sourced from the PT. Dutabahari Menara Line Dockyard which has been approved by the Indonesian Classification Bureau and jetty or dock data sourced from the PELINDO III website. The primary data collected, among others, are in Table 1 and Table 2.

Table 1. Dimension of ship

Dimension	value	unit
Length Overall	71,4	m
B	16,80	m
H	4,40	m
T	3,60	m
DWT	3500	ton

Table 2. Dimension of Jetty

Dimension	value	unit
L	7,0	m
B	4,5	m
H	5,5	m

The meshing process is carried out to adjust the distance between elements, which must be analyzed using finite element-based software before proceeding to the processing stage.[5][18] In the meshing steps carried out as follows, Click

Mesh on the Outline then on the Detail of "Mesh" in the lower left corner, in the Defaults table, the Element Order is changed to linear and the Element Size used is 200 mm. Then in the Sizing table, Transition is changed to slow and Span Angle Center is changed to Fine with the aim of smoothing curved geometric surfaces.[1][19]

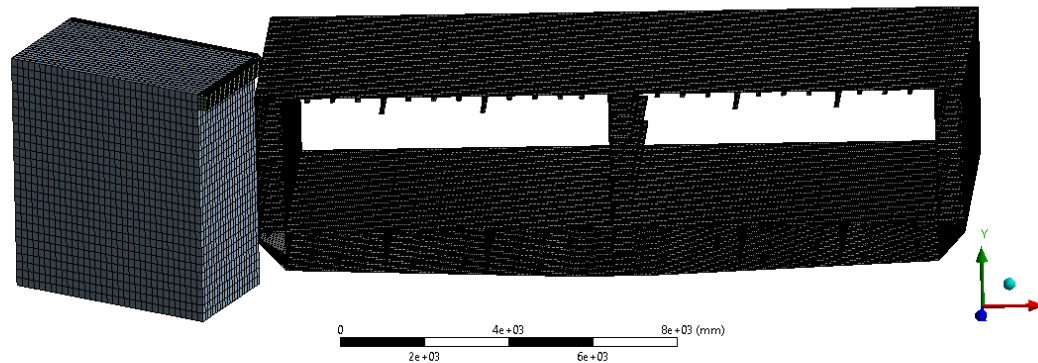

Figure 4. Boundary Conditions.

the load used on the model of the ship hitting a jetty that is not equipped with fenders and the ship hitting a jetty equipped with fenders, namely using the calculation of the impact force which has been calculated using equation (2.1) and using speed variations of 0,5m/s, 1m/s, and 2m/s where the results can be seen in Table 3.

Table 3. Impact Force Value based On Velocity Variation

Velocity Variation (m/s)	Force (MN)
0.5	3,518300621
1	7,036601241
2	14,07320248

The load used on the model of the ship hitting a jetty that is not equipped with fenders and the ship hitting a jetty equipped with fenders is using the calculation of the impact force which has been calculated using equation 1 and using speed variations of 0.5m/s, 1m/s, and 2m/s where the results can be seen in Table 3.

The value of the impact force (P) used in the case of a hull collision with a jetty can use the equation according to the AASHTO specification.

$$P = 8,15 \times V \times \sqrt{DWT} \quad (1)$$

Where V is the speed of the ship when it will experience a collision, and DWT is the dead weight of the ship.

Deformation can occur when a material experiences a force. While deformation occurs, energy will be absorbed by the material resulting in the presence of the force acting during the deformation. No matter how small the force acting, the object will change shape and size. [20][21] This physical change in size is called deformation. There are two kinds of deformation, namely elastic deformation and plastic deformation. [22][23] What is meant by elastic deformation is the deformation that occurs due to a load which if the load is removed, the material will return to its original size. Meanwhile, plastic deformation is permanent deformation if the load is removed [2] [24][25][26].

$$\delta = \frac{F \times L}{A \times E} = \sigma \frac{L}{E} \quad (2)$$

Where:

F: Force (N)

A: Surface Area (mm²)

L: Initial Length (mm)

E: Elasticity Modulus

σ : Stress (N/mm²)

3. Results and Discussion

In this research, it is known that model 1 (one) is a model of a ship hitting a jetty that is not equipped with fenders and model 2 (two) is a ship hitting a jetty equipped with a fender that has been processed with a predetermined speed variation as shown below, the stress graph can be seen in Fig. 11.

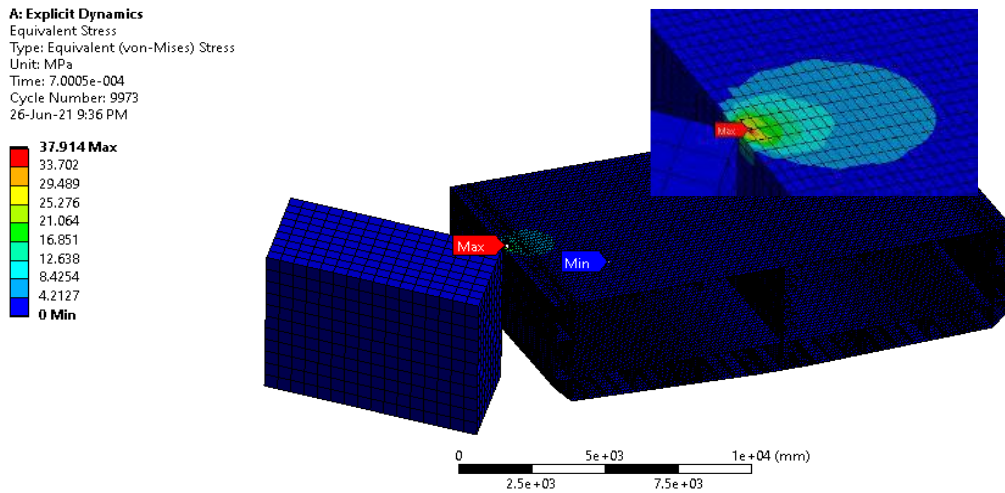

Figure 5. The Result of Model 1 Stress Value at a Speed of 0,5 m/s

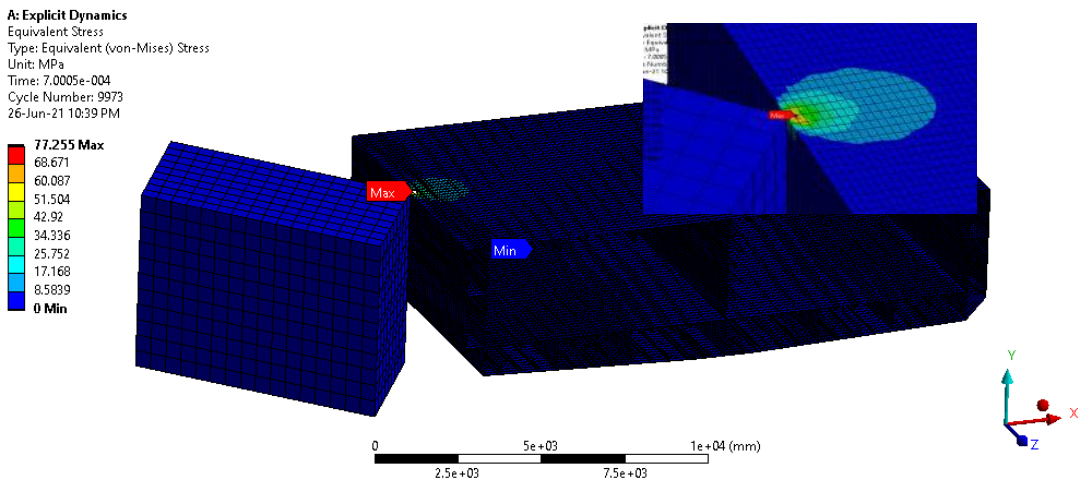

Figure 6. The Result of Model 1 Stress Value at a Speed of 1 m/s

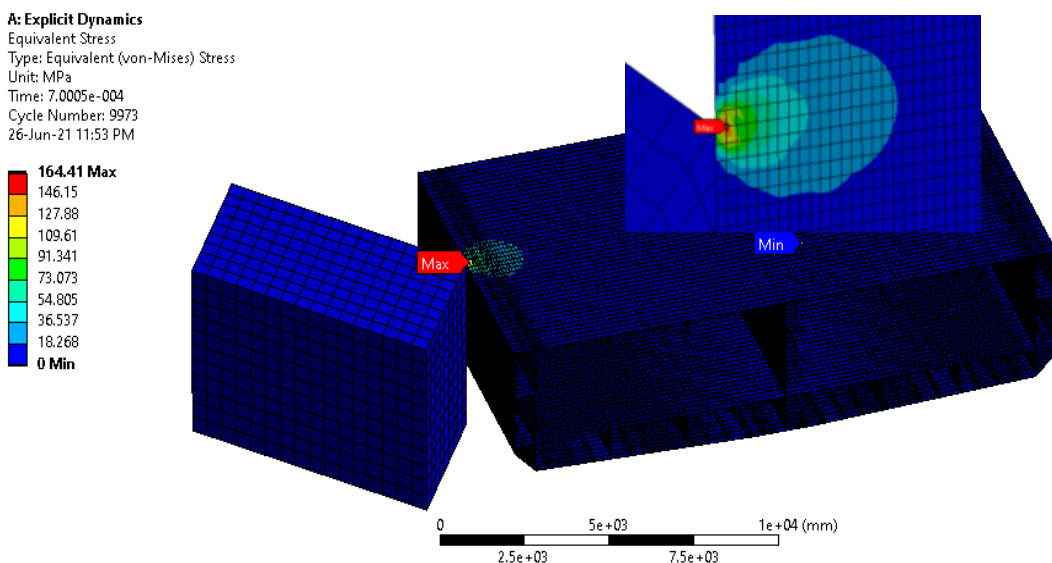

Figure 7. The Result of Model 1 Stress Value at a Speed of 2 m/s

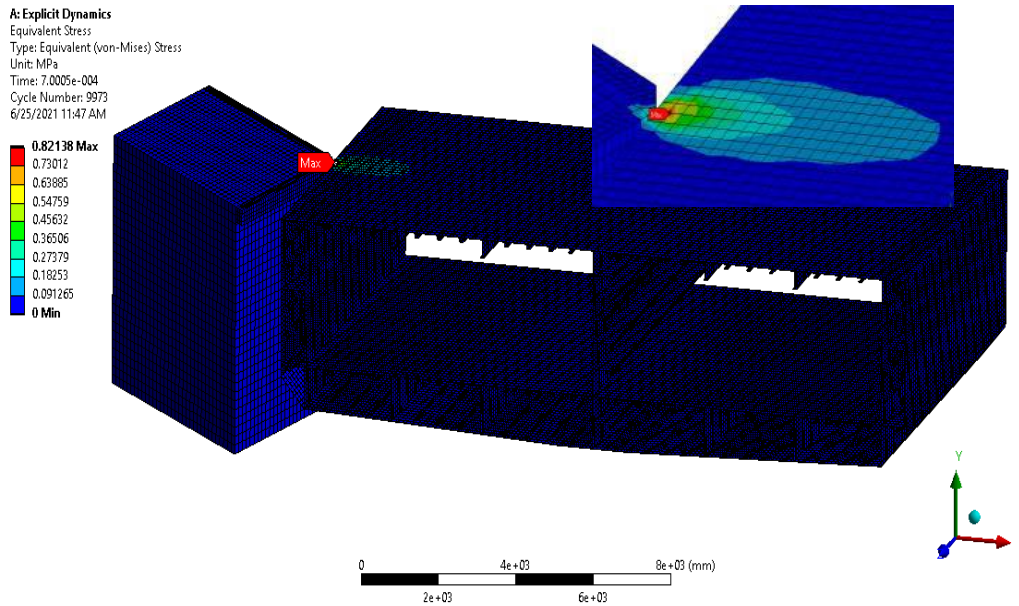

Figure 8. The Result of Model 2 Stress Value at a Speed of 0,5 m/s

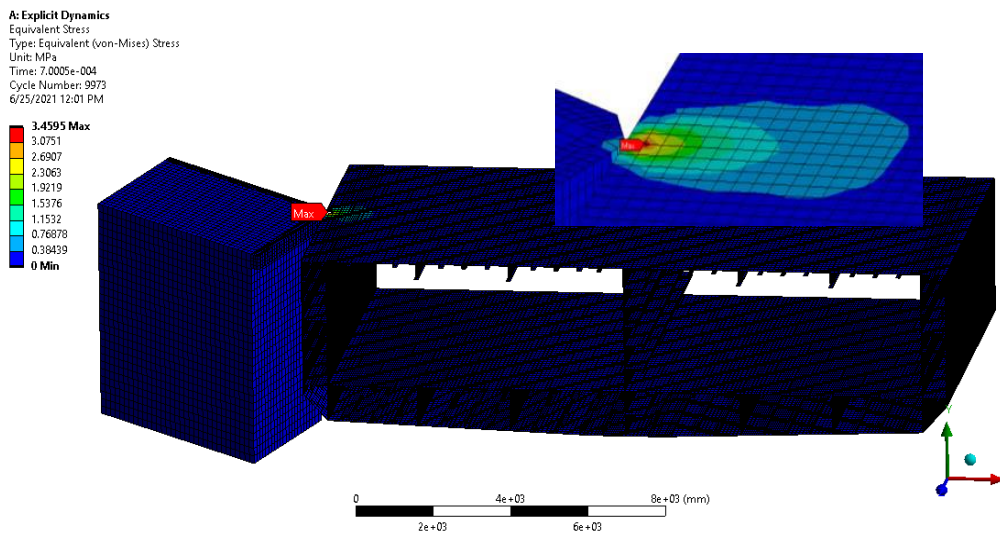

Figure 9. The Result of Model 2 Stress Value at a Speed of 1 m/s

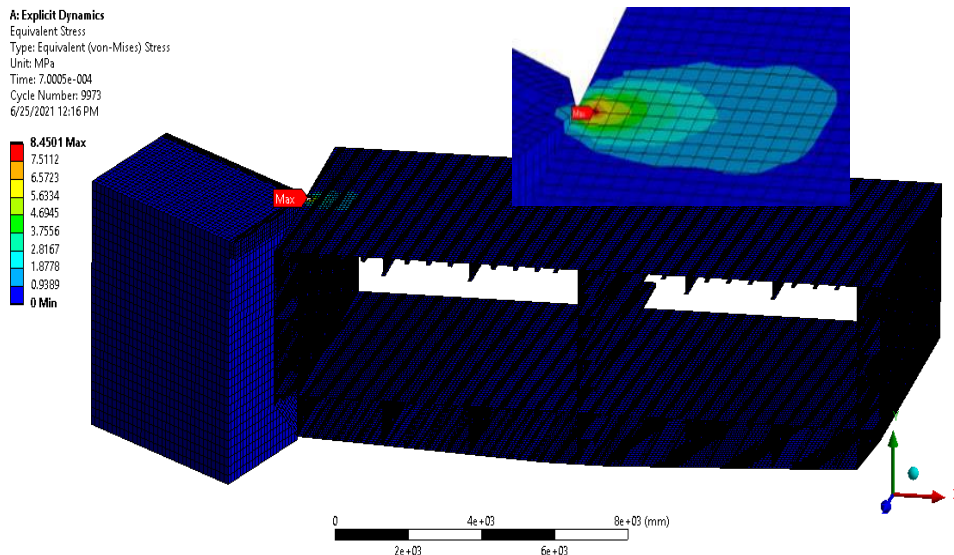

Figure 10. The Result of Model 2 Stress Value at a Speed of 2 m/s

Stress and Velocity

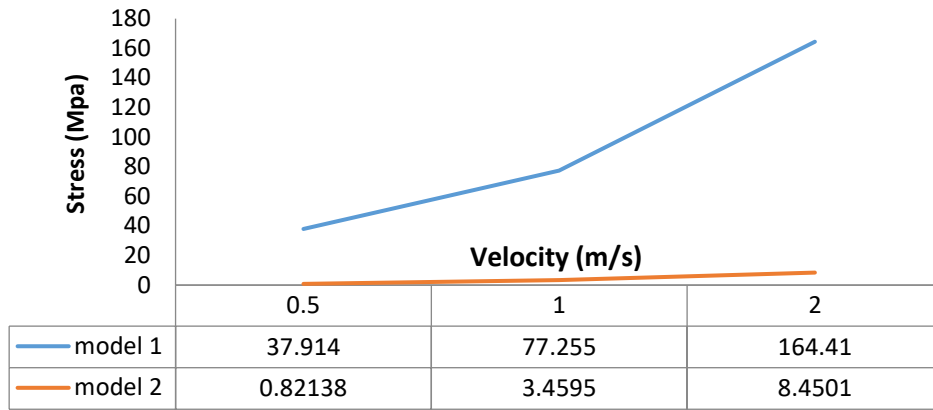

Figure 11. Graph of Stress Value in 2 Model

In the research, it is known that model 1 (one) is a model of a ship hitting a jetty that is not equipped with fenders and model 2 (two) is a ship hitting a jetty equipped with a fender that has been processed with a predetermined speed variation as shown below, the deformation graph can be seen in Fig. 17 .

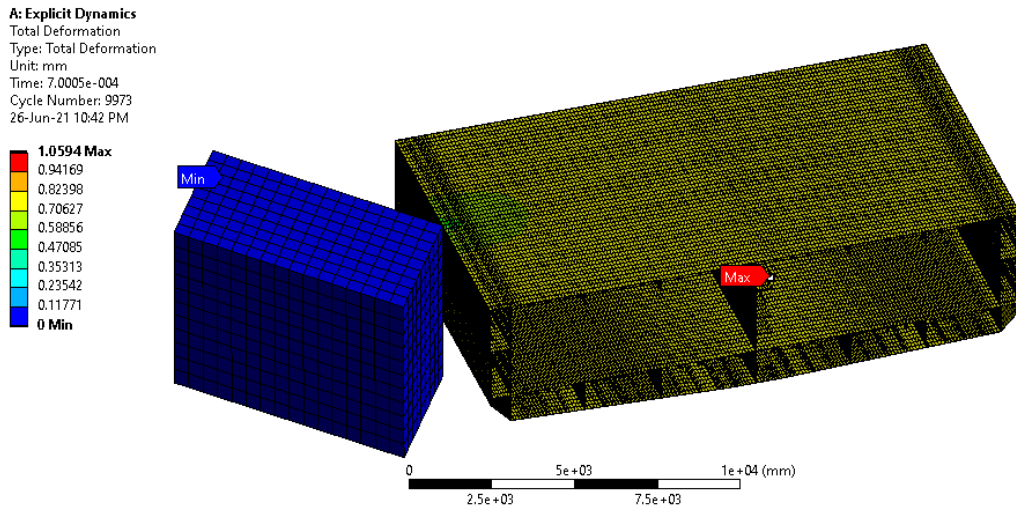

Figure 12. The Result of Model 1 Deformation Value at a Speed of 1 m/s

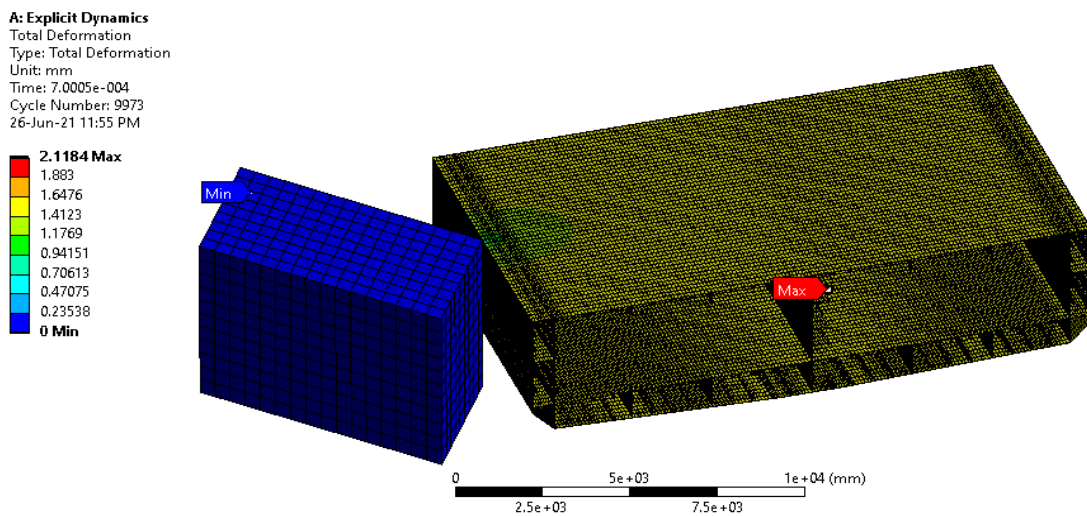

Figure 13. The Result of Model 1 Deformation Value at a Speed of 2 m/s

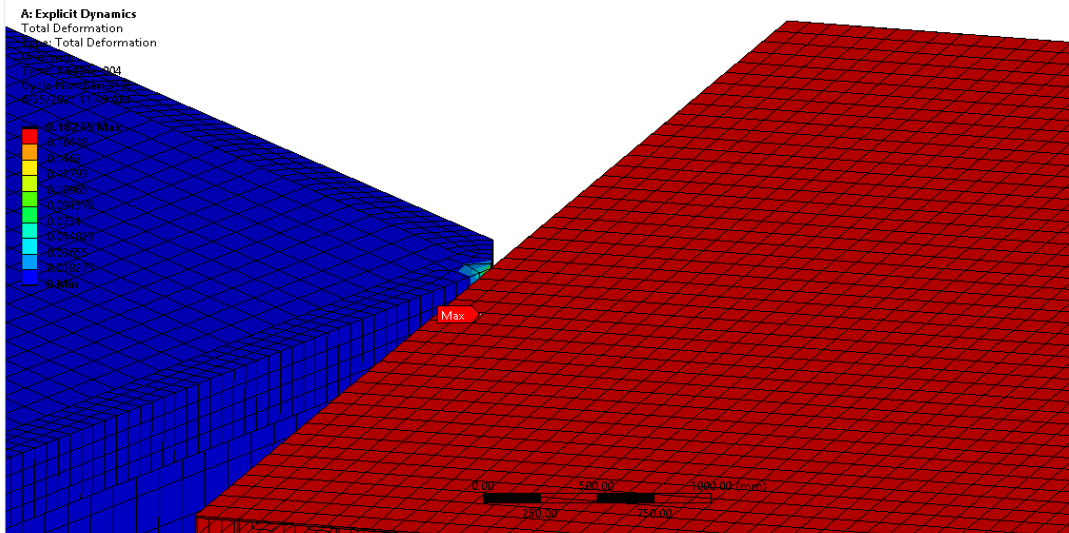

Figure 14. The Result of Model 2 Deformation Value at a Speed of 0.5 m/s

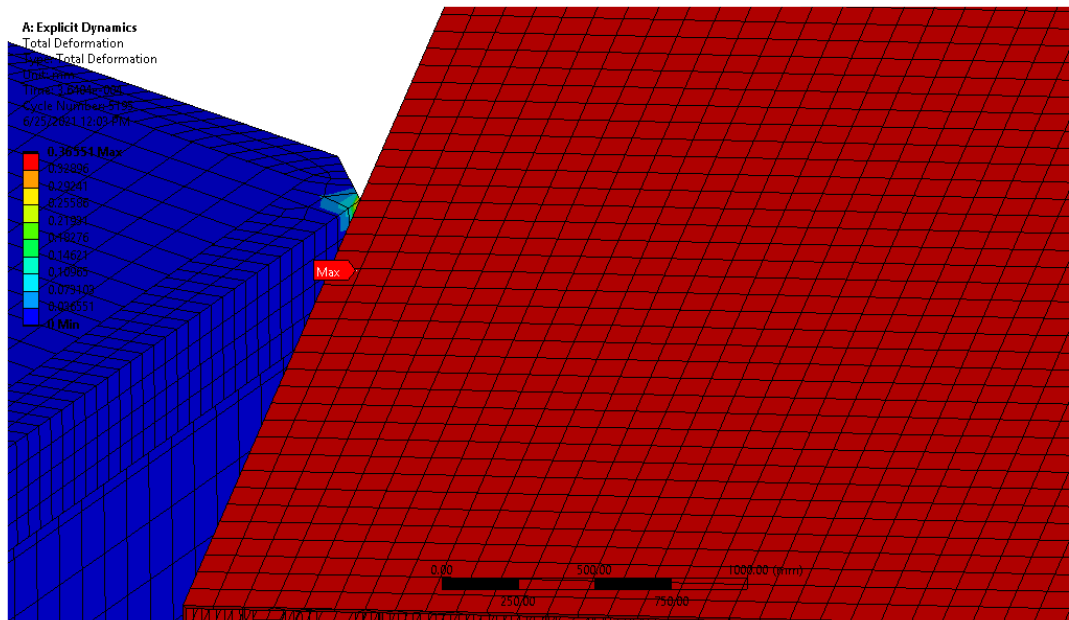

Figure 15. The Result of Model 2 Deformation Value at a Speed of 1 m/s

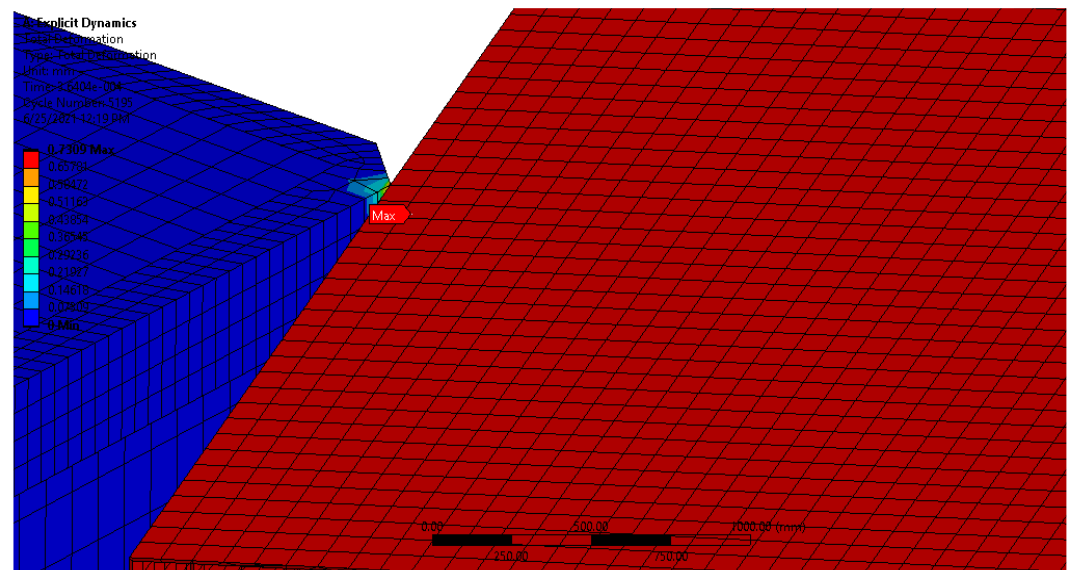

Figure 16. The Result of Model 2 Deformation Value at a Speed of 2 m/s

Deformation and Velocity

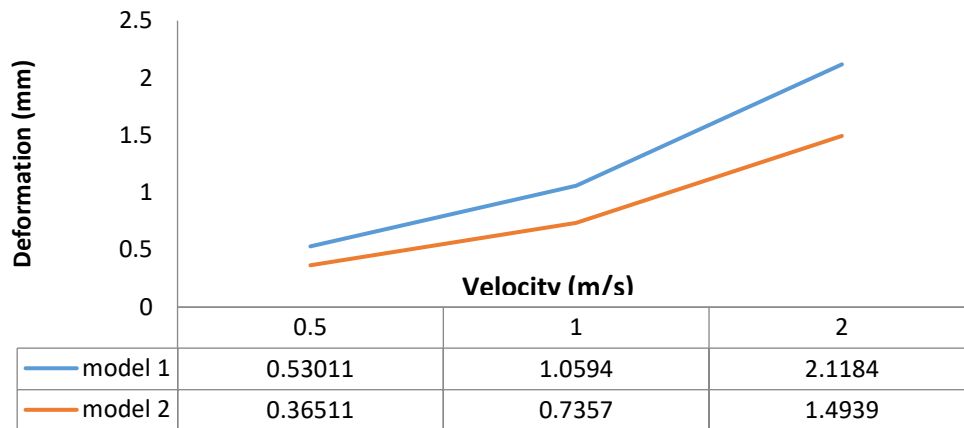

Figure 17. Graph of Deformation Value in 2 Model

After obtaining the results of stress calculations using finite element-based software, it was found that the maximum stress was on the side of the ship that hit the jetty that was not equipped with fenders with a speed variation of 2 m/s. The maximum stress obtained from each model is then compared with the ultimate stress, the material yields according to the material certificate based on BKI Vol V 2019 Sec 4 B 6.5 as shown in Table 4 and Table 5 as follows.

Table 4. Comparison of Model 1 Maximum Stress with Ultimate Stress and Yield Stress

Velocity Variation (m/s)	Maximum Stress (Mpa)	Ultimate Stress (Mpa)	Yield Stress Material (Mpa)	Stress Status
0.5	37.914	440	355	Accepted
1	77.255	440	335	Accepted
2	164.41	440	335	Accepted

Table 5. Comparison of Model 2 Maximum Stress with Ultimate Stress and Yield Stress

Velocity Variation (m/s)	Maximum Stress (Mpa)	Ultimate Stress (Mpa)	Yield Stress Material (Mpa)	Stress Status
0.5	0.82138	440	355	Accepted
1	3.4595	440	335	Accepted
2	8.4501	440	335	Accepted

After obtaining the results of the calculation of deformation using finite element-based software and the maximum stress in each model which is then compared with the allowable deformation based on IACS Recommendation No. 47, we get Table 6 and Table 7 as follows,

Table 6. Deformation value on Model 1

Velocity Variation (m/s)	Deformation (mm)	Deformation Limit (mm)	Status
0.5	0.53011	8	Accepted
1	1.0594	8	Accepted
2	2.1184	8	Accepted

Table 7. Deformation value on Model 2

Velocity Variation (m/s)	Deformation (mm)	Deformation Limit (mm)	Status
0.5	0.36511	8	Accepted
1	0.7357	8	Accepted
2	1.4939	8	Accepted

4. Conclusion

The conclusions obtained after conducting this research are as follows:

1. Damage to the ship's hull can be known based on the deformation value that has been obtained indicating that the damage will increase with increasing ship speed. But if the jetty is equipped with or installed fenders, then the damage can be reduced. With the deformation values in the model of the ship hitting a jetty that is not equipped with fenders which are calculated at a speed of 0.5 m/s, 1m/s and 2m/s respectively, 0.53011 mm, 1.0594 mm, and 2.1184 mm. And the value of deformation on the model of the ship hitting a jetty equipped with fenders which is calculated at a speed of 0.5 m/s, 1m/s and 2m/s respectively is 0.36511 mm, 0.7357 mm, and 1.4939 mm.
2. The calculated force values with velocities of 0.5 m/s, 1m/s and 2m/s respectively are 3.52 MN, 7.04 MN, and 14.07 MN. The stress value on the model ship hitting a jetty that is not equipped with a fender is calculated at a speed of 0.5 m/s, 1m/s and 2m/s respectively of 37,914 MPa, 77,255 MPa, and 164.41 MPa. And the stress values on the model ship hitting a jetty equipped with fenders are calculated at a speed of 0.5 m/s, 1m/s and 2m/s respectively at 0.82138 Mpa, 3.4595 Mpa, and 8.4501 Mpa.

References

- [1] M. S. Zala and P. Kunal, " Design Analysis and Optimization of Parallel Motion Fender," *International Journal Advance Engineering and Research Development*, vol. 2, no. 05, pp. 105– 107, 2015, doi: [10.21090/ijaerd.0205161](https://doi.org/10.21090/ijaerd.0205161)
- [2] Z. M. S, K. J. Motwani, and N. J. Patel, " Design Analysis and Optimization of Parallel Motion Fender," *International Journal Advance Engineering and Research Development*, vol. 2, no. 05, pp. 1144– 1149, 2015.
- [3] Y. Zheng, X. Zhang, Z. Shang, S. Guo, and Y. Du, " A Decision-Making Method for Ship Collision Avoidance Based on Improved Cultural Particle Swarm," *Journal Advance Transportation*, vol. 2021, 2021, doi: [10.1155/2021/8898507](https://doi.org/10.1155/2021/8898507)
- [4] J. Weng and S. Xue, " Ship collision frequency estimation in port fairways: A case study," *Journal Navigation*, vol. 68, no. 3, pp. 602– 618, 2015, doi: [10.1017/S0373463314000885](https://doi.org/10.1017/S0373463314000885)
- [5] E. Avi, A. Laakso, J. Romanoff, H. Remes, and I. Lillemäe-Avi, " Coarse mesh finite element model for cruise ship global and local vibration analysis," *Marine Structures*, vol. 79, 2021. doi: [10.1016/j.marstruc.2021.103053](https://doi.org/10.1016/j.marstruc.2021.103053)
- [6] M. Heinvee and K. Tabri, " A simplified method to predict grounding damage of double bottom tankers," *Marine Structures*, vol. 43, pp. 22– 43, 2015. doi: [10.1016/j.marstruc.2015.04.002](https://doi.org/10.1016/j.marstruc.2015.04.002)
- [7] R. P. Schoeman, C. Patterson-Abrolat, and S. Plön, " A Global Review of Vessel Collisions With Marine Animals," *Frontier Marine Science*, vol. 7, pp. 1– 25, 2020. doi: [10.3389/fmars.2020.00292](https://doi.org/10.3389/fmars.2020.00292)
- [8] M. Angel, G. Calle, and M. Alves, " Ship collision : A brief survey SHIP COLLISION," , 2016.
- [9] H. Hasanudin, W. D. Aryawan, A. Zubaydi, and T. Putranto, " Dynamics Finite Element for Ship Damage Collision Analysis," *IPTEK J. Proc. Ser.*, vol. 0, no. 2, p. 120, 2017.
- [10] P. J. Kocke, " Impact Damage Between the Collision of a Vessel And Protective Fender Systems," 2008.
- [11] R. B. Mitson, *Underwater Noise Of Research Vessels*. Denmark: International Council for the Exploration of the Sea Palzgade 2 - 4, DK-126 1 Copenhagen K Denmark.
- [12] L. De Gracia, H. Wang, W. Mao, N. Osawa, I. Rychlik, and G. Storhaug, " Comparison of Two Statistical Wave Models For Fatigue And Fracture Analysis Of Ship Structures," *Ocean Engineering*, vol. 187, pp. 106161, 2019. doi: [10.1016/j.oceaneng.2019.106161](https://doi.org/10.1016/j.oceaneng.2019.106161)
- [13] C. M. D. Wilson, N. Yazdani, and J. Wekezer, " Static Finite-Element Analysis of Bridge Fenders for Barge Impact," *Journal Performance Constructed Facilities*, vol. 15, no. 3, pp. 90– 95, 2001. doi: [10.1061/\(ASCE\)0887-3828\(2001\)15:3\(90\)](https://doi.org/10.1061/(ASCE)0887-3828(2001)15:3(90))
- [14] L. Zhang, H. Wang, Q. Meng, and H. Xie, " Ship accident consequences and contributing factors analyses using ship accident investigation reports," *Proceedings Institution Mechanical Engineers Part Of Journal Risk Reliability*, vol. 233, no. 1, pp. 35– 47, 2019.
- [15] A. R. Prabowo, T. Putranto, and J. M. Sohn, " Simulation of the Behavior Of A Ship Hull Under Grounding: Effect Of Applied Element Size On Structural Crashworthiness," *Journal of Marine Science Engineering*, vol. 7, no. 8, 2019. doi: [10.3390/jmse7080270](https://doi.org/10.3390/jmse7080270)
- [16] A. R. Prabowo and D. M. Bae, " Environmental Risk Of Maritime Territory Subjected To Accidental Phenomena: Correlation Of Oil Spill And Ship Grounding In The Exxon Valdez' s Case," *Results Engineering*, vol. 4, pp. 100035, 2019. doi: [10.1016/j.rineng.2019.100035](https://doi.org/10.1016/j.rineng.2019.100035)
- [17] X. Bi and X. Liu, " Research on Double Collision Avoidance Mechanism of Ships at Sea," *TransNav, International Journal Marine Navigation Safety Sea Transportation*, vol. 9, no. 1, pp. 13– 16, 2015. doi: [10.12716/1001.09.01.01](https://doi.org/10.12716/1001.09.01.01)
- [18] I. Lotsberg, " Assessment Of The Size Effect In Fatigue Analysis Of Butt Welds And Cruciform Joints," *Proceedings International Conference Offshore Mechanical Architecture Engineering - OMAE*, vol. 5, 2014. doi: [10.1115/OMAE2014-23187](https://doi.org/10.1115/OMAE2014-23187)
- [19] L. P. Adnyani, M. A. M. Arsyad, and S. D. Nurcholik, " Analysis of Fatigue Life of Tugboat Towing Hook Construction Using Finite Element Method," *Kapal: Jurnal Ilmu Pengetahuan dan Teknologi Kelautan*, vol. 17, no. 2, pp. 86– 94, 2020. doi: [10.14710/kapal.v17i2.29587](https://doi.org/10.14710/kapal.v17i2.29587)
- [20] I. G. M. S. Adhita and M. Furusho, " Ship-to-Ship Collision Analyses Based on Functional Resonance Analysis Method," *Journal ETA Maritime Science*, vol. 9, no. 2, pp. 102– 109, 2021.
- [21] T. Chai and H. Xue, " A study on ship collision conflict prediction in the Taiwan Strait using the EMD-based LSSVM method," *PLoS One*, vol. 16, 2021.
- [22] S. Heinz and D. Eifler, " Very high cycle fatigue and damage behavior of Ti6Al4V," *Key Engineering Material*, vol. 664, pp. 71– 80, 2016.

- [23] M. Riesner and O. el Moctar, " Assessment of wave induced higher order resonant vibrations of ships at forward speed," *Journal Fluids Structure*, vol. 103, pp. 103262, 2021.
- [24] M. Z. M. Alie and S. I. Latumahina, " Progressive collapse analysis of the local elements and ultimate strength of a Ro-Ro Ship," *International Journal Technology*, vol. 10, no. 5, pp. 1065– 1074, 2019. doi: [10.14716/ijtech.v10i5.1768](https://doi.org/10.14716/ijtech.v10i5.1768)
- [25] A. I. Wulandari, N.W.D. Rahmasari, L.P. Adnyani, Alamsyah, R. J. Ikhwani, " Fatigue Analysis Of5000 GT Ferry Ro-Ro s Car Deck Using Finite Element Method," *Kapal: Jurnal Ilmu Pengetahuan dan Teknologi Kelautan*, vol. 18, no. 3, pp. 160– 170, 2021. doi: [10.14710/kapal.v18i3.39268](https://doi.org/10.14710/kapal.v18i3.39268)
- [26] M. Z. M. Alie, I.M. Suci, G. Sitepu, " Longitudinal Strength Analysis Considering the Cargo Load on Very Large Crude Carrier (VLCC)," *Kapal: Jurnal Ilmu Pengetahuan dan Teknologi Kelautan*, vol. 18, no. 3, pp. 171– 177, 2021.