

## Mercury Elemental Storage Tank Design

Elvi Restiawaty<sup>1,2,3,\*</sup>, Yazid Bindar<sup>2</sup>), Christian Aslan<sup>3</sup>), and Alif Lutfia Masduqi<sup>3</sup>)

<sup>1</sup>)Research Group of Chemical Engineering Process Design and Development, Faculty of Industrial Technology, Institut Teknologi Bandung, Jl. Ganesha 10, Bandung 40132, Indonesia.

<sup>2</sup>) Study Program of Bioenergy Engineering and Chemurgy, Faculty of Industrial Technology, Institut Teknologi Bandung.

<sup>3</sup>) Biosciences and Biotechnology Research Center, Institut Teknologi Bandung.

\*) Corresponding author: [erestiawaty@che.itb.ac.id](mailto:erestiawaty@che.itb.ac.id)

(Received : October 24, 2019; Accepted: April 14, 2020)

### Abstract

*Mercury is a liquid metal that has properties such as toxic, persistent, bioaccumulating, and its vapor can spread around sources so that it is harmful to humans. Despite having dangerous properties, mercury is found in some goods, products, and also waste. Mercury is indicated to be used in several industries, such as artisanal and small-scale gold mining and coal-fired steam power plants. Based on health and environmental considerations, mercury must ultimately be removed from the eco cycle. Mercury storage systems in the long term must be solved so that sustainable development for future generations can be achieved. Currently, there is still no mercury storage system in Indonesia with a good standard design, so the conceptual design study of the mercury elemental storage system is important. In this paper, the storage tanks with a mercury capacity of 35 kilograms, one tonne, and two tonnes were designed to meet mercury storage standards. Several design criteria were used as model development, such as storage capacity, height level, safety factor material, storage temperature, tank life span, and symbols and label. The design results presented in this paper are dimension and engineering drawing of the storage tanks and attributes like spill tray, pallet, and rack.*

**Keywords:** *environment; hazardous and toxic material; Indonesia; mercury; storage tanks*

**How to Cite This Article:** Restiawaty, E., Bindar, Y., Aslan, C., and Masduqi, A.L. (2020), Mercury Elemental Storage Tank Design, Reaktor, 20(2), 57-67, <https://doi.org/10.14710/reaktor.20.2.57-67>

### INTRODUCTION

The development of a storage system for handling dangerous and toxic materials is very important. Mercury is a liquid metal that is harmful to humans and the environment, so its storage needs to be very well designed. Mercury is used in several done by inhalation, digestion, injection, and skin permeation. There are three forms of mercury, which is elemental mercury, inorganic mercury, and organic

products and industrial processes. The mercury used in the open system will cause vapor emissions into the air and the spill must be treated seriously. Mercury is very poisonous and can affect biological processes in the soil which can cause serious harm to humans and animals. Mercury poisoning to the human body can be mercury. Mercury in the form of methyl mercury can damage the central nervous system and is very dangerous for fetuses and children. The accumulation

of methyl mercury in the food chain can cause even more serious damage (Broussard *et al.*, 2002).

Most of the mercury emission is from human activity. Artisanal and small-scale gold mining (ASGM) and coal-fired power plants are two major contributors to mercury emission, respectively 37 and 24 percent (UNEP, 2013). There are more than 150,000 workers in around 850 artisanal and small-scale gold mining in Indonesia (Ismawati, 2010). Based on the study in Indonesia in 2012, mercury was released to the environment 339,250 kg/year, with 59.37% released to the air, 15.5% released to water, and approximately 14% released to soil/sediment. About 57.5% of this emission was from the artisanal and small-scale gold mining with the total emissions of 195 tonnes/year, or approximately 20% from the global artisanal and small-scale gold mining total emissions (Dewi, 2012).

There are many methods to handle mercury pollution in Indonesia, by preventive or curative. For example, the prohibition of mercury usage, production, and trading, mercury emission control to the air, water, and soil, remediation of the contaminated area, and development of mercury storage. Mercury usage, production, and trading can be reduced and replaced by the usage of alternatives to mercury-added products, such as the usage of digital thermometers rather than mercury thermometers. Mercury emission can be controlled by the development of waste treatment. Remediation of the contaminated area can be done by soil washing, stabilization (solidification), and phytoremediation, and bacterial remediation. Mercury storage facilities can be designed to store and place mercury in the form of pure or waste materials (Science for Environment Policy, 2017).

In this research, the main focus was the development of mercury storage areas which are built at several places in Indonesia. As previously stated, mercury vapor is very dangerous if inhaled by humans, so the design of the storage system needs special attention and must be done very well and carefully. Mercury storage facilities must be well designed and taking into account the physicochemical properties of the materials and the standard design requirements for

the storage of hazardous and toxic materials. The conceptual design study of the mercury storage system is very important because a good mercury storage system that meets the storage standards of hazardous and toxic materials in the form of liquid metal is not yet available in Indonesia.

## MODEL DEVELOPMENT

There were some mercury elemental storage tank design criteria that were taken into account, i.e. storage capacity, mercury height level, safety factor material, storage temperature, tank life span, and symbols and label.

### Storage Capacity

Storage capacity is one of the important design criteria. The tank can be designed in small-type (one or two tonnes) or large-type (50 tonnes). The choice of storage capacity type is influenced by many factors, such as costs, safety, or handling. The differences are showed in Table 1.

International Maritime Organization (IMO, 2006) regulate that mercury transported by waterway is not more than 3 liters (40.8 kilograms). Moreover, the International Air Transport Association (IATA, 2006) regulates that mercury transported by airway is not more than 35 kilograms, not including the mass of the container. Therefore, a 35-kilogram tank must be designed to facilitate waterway and airway transportation.

Based on the preliminary study, the tanks were designed in 35 kilograms (35-KG), one tonne (1-T), and two tonnes (2-T). The capacity is common and standard for mercury storage (Carroll, 2009). The comparison analysis of these types is shown in Table 2 **Error! Reference source not found.** The comparison analysis emphasized on function, simplicity of transportation, transportation lane, handling in the storage area, and economy of the tank designs.

### Material

The material used in the manufacture was carbon steel with sandblasting and polyurethane coating inside and epoxy-based painting outside.

Table 1. Differences of small-type and large-type of the storage tank

Aspect	Small-type tank	Large-type tank	References
Cost	Manufacture cost is more expensive	Manufacture cost is less expensive	Carroll (2009)
Safety (in case of failure or leakage)	It is easier to handle because the tank volume is smaller	It is harder to handle because the tank volume is larger	Crowl and Louvar (2011)
Handling	Easier to transport in the same storage area by forklift	Harder to move in the same storage area by forklift	Carroll (2009)
Simplicity of Transportation	Transportation to another area is still possible	Transportation to another area is impossible	Carroll (2009)
Frequency of use	Common to use in mercury storage facilities in the USA	Rare to use in the world	U.S. DOE (2010)

Table 2. Comparison analysis the storage tanks

Aspect	35-KG	1-T	2-T
Function	Temporary storage tank to collect elemental mercury at a far place from the facility	Mercury storage tank (40 years life) that has a capacity of 1-T	Mercury storage tank (40 years life) that has a capacity of 2-T
Simplicity of Transportation	Easy to transport	Still possible to transport	Still possible to transport, but not recommended
Transportation Lane	Land way, waterway, and airway (Indonesia Ministry of Transportation, 2004, IATA, 2006, and IMDG, 2006)	Only land way (Indonesia Ministry of Transportation, 2004, IATA, 2006, and IMDG, 2006)	Only land way (Indonesia Ministry of Transportation, 2004, IATA, 2006, and IMDG, 2006)
Handling in the storage area	Pallet and forklift are used	Hooks and forklift are used	Hooks and forklift are used
Economy	Lowest efficiency index, the greatest amount of steel used for storing mercury increasing cost (Carroll, 2009)	Improved efficiency index over 35-KG tanks (Carroll, 2009), and greatly reduced floor space requirements compared to the 35-KG tanks (Carroll, 2009)	Reduced floor space requirements by approximately 30% from 1-T tanks' floor space requirement (Carroll, 2009)

Carbon steel was selected for strength, ease of fabrication, and inexpensive cost (Roberge, 2008). Stainless steel was not selected because the cost is more expensive, and mercury can adhere to stainless steel that will harder clean. Polyurethane was selected because polyurethane is a polymer with no halogen matter, so mercury will not adhere to this type of polymer. Polyurethane was also used as a material for hose inside tanks. The gray color is used for epoxy paint outside the tank.

#### Mercury Level

Mercury is a liquid metal that easily evaporates, so some empty space is needed to hold the mercury vapor. The tanks need a ten percent empty space (US DOE, 2009). It means the maximum capacity for the 35-KG (2.6 liters), 1-T, and 2-T tanks respectively are 3 liters, 1.1 tonnes, and 2.2 tonnes.

#### Safety Factor Material

Safety factor material is needed to bear against a load of operating design conditions like the weight of the tank, hydrostatic pressure of the mercury inside the tank, and gas pressure inside the tank. If the stress is higher than yield strength, the material will receive plastic deformation. Moreover, if the stress is higher than the tensile strength, the material will be fractured. Safety factor material is a ratio between yield strength and stress. The stress must not greater than one-third of the yield strength (API 620, 2013).

#### Temperature

Storage temperature is an important factor because mercury elemental is very easy to evaporate (Broussard et al., 2002). Based on Meteorological, Climatological, and Geophysical Agency (2018), the prediction of range temperature in Indonesia from 2019 until 2059 is 23.4°C to 33.9°C, so the storage tank must be designed to bear against that range temperature.

#### Life Span

United States Department of Energy planned to build a mercury elemental storage facility that has a 40 years life span (US DOE, 2010). The 40-years life span is used as criteria, but these criteria are only for capacity 1-T and 2-T. For the 35-KG tank, the life span design is only 10 years.

#### Corrosion Allowance

The corrosion rate of carbon steel in the mercury waste tank is 5 mpy (0.127 mm per year) (Kranzlein, 1959). Referring to the lifespan of the tanks and the corrosion rate information, the corrosion allowance of the 35-KG, 1-T, and 2-T tanks are 1,25 mm, 5 mm, and 5 mm, respectively.

#### Additional Attributes: Spill Tray, Pallet, and Rack

Spill tray, pallet, and rack are designed referring to US DOE (Oak Ridge National Laboratory, 2009). Spill tray is used to collect the mercury when a leak occurs. The pallet is used as a container to transport the tank. The rack is used to placing the pallets.

#### Additional Attributes: Symbol and Label

Symbol and label are used as a mark for hazardous and toxic material storage, handling, and treatment. Symbols show the classifications of hazardous and toxic material. The label shows a short description of hazardous and toxic material. The symbols and label were designed referring to Ministerial Regulation of Indonesia Ministry of Environment Number 03 Year 2008 about Procedures for Giving Symbols and Labels of Hazardous and Toxic Materials (Indonesia Ministry of Environment and Forestry, 2008) and Material Safety Data Sheet of Mercury (Fisher Scientific, 2009 and Thermo Fisher Scientific, 2019).

## RESULTS AND DISCUSSION

### Tank Capacity and Mass

The tank dimensions were chosen with a height to diameter ratio close to one for safety and economic reasons. Table 3 shows the diameter and height of storage tanks. Table 4 shows the mass of the mercury tank.

Table 3. Diameter and height of storage tanks

Tank Type	Outer diameter	Inner diameter	Inner height
35-KG	168 mm	161 mm	150 mm
1-T	508 mm	483 mm	485 mm
2-T	610 mm	585 mm	650 mm

Table 4. Mass of the mercury tank

Tank Type	Mass without mercury	Mass with mercury
35-KG	5 kg	40 kg
1-T	125 kg	1125 kg
2-T	190 kg	2190 kg

### Shell

Shell is the main body part of the tank. Shell thickness was determined by the strength of the structure and corrosion rate of the material. Table 5 shows the shell thickness. The shell design is depicted in

Figure 1.

Table 5. Shell Thickness

Tank Type	Thickness determined by the strength of the structure	Corrosion allowance	Final thickness design
35-KG	2,25 mm	1,25 mm	3,5 mm
1-T	5 mm	5 mm	12,5 mm
2-T	7 mm	5 mm	12,5 mm



Figure 1. Shell design

### Head

The shape of the head is torispherical. Torispherical shape was used because the knuckle radius could reduce the risk of collision. The head had the same thickness with the shell and obeyed the minimum head thickness in API 650 (5 mm) (API 650, 2013), except 35-KG tank. This exception was given because even though the head of the tank would be subjected to pressure from mercury vapor, there would be only a small amount of mercury vapor at room temperature, so the pressure produced would be small.

The head height of the head storage tank for 35-KG, 1-T, and 2-T tanks were 20 mm, 98 mm, and 98 mm, respectively. The 35-KG tank head had two holes for mechanical valve and level indicator, but the 1-T or 2-T tank head had only one hole which attaches with the neck. The head design before perforated is shown in Figure 2.



Figure 2. Head design

### Neck

The neck was attached to the head hole. The neck only existed on 1-T and 2-T tanks. The dimension of the neck was approximately the same as the head hole. The neck design is similar to shell design and is shown in Figure 3.



Figure 3. Neck design

### Flange

Slip flange and blind flange were attached to the upside of the neck. Both only exists on 1-T and 2-T tanks. Flanges were used to simplify tank cleaning. The flange had eight fasteners with a diameter of 13 mm on the edge. The center hole dimension on the slip flange was approximately the same as the neck design. Besides that, the blind flange had two holes in the center which fits with the mechanical valve and level indicator dimension. Slip flange and blind flange design are shown in Figure 4.



Figure 4. (a) Slip flange and (b) blind flange

### Bottom

The shape of the bottom was torispherical without a hole. The reason was to ease mercury pumping from the tank to tank and to ease tank cleaning. The shape and dimension of the bottom were similar to the head, so the tank could stand well and stable. The bottom design is shown in

Figure 5.



Figure 5. Bottom design

**Handle and Lugs**

Handles are important to move the tanks. The 35-KG tank had one round-shaped handle which attaches with the head of the tank, so it could be moved easily with a handgrip. Meanwhile, 1-T and 2-T tank had three lugs attached with the head of the tank. Each of the lugs would be attached to a hook that is connected to the forklift. The handle design and lug design are shown in Figure 6.



Figure 6. (a) Handle design of 35-KG tanks and (b) lug design of 1-T or 2-T tanks

**Feet**

The feet are used to support the tank, so the tank can stand well and does not fall easily. In addition, the feet also prevent outside contact of the tank wall with mercury when a leak occurs. The feet were attached to the bottom of the tank. The 35-KG tank had one ring-shaped foot, but the 1-T and 2-T tank had four square-shaped feet.

Figure 7 shows the ring-shaped foot and 4 square-shaped feet.

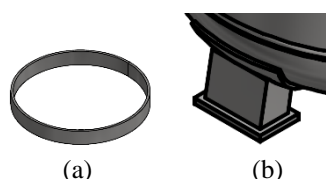

Figure 7. Foot design of (a) 35-KG tanks and (b) 1-T or 2-T tanks

**Spill Tray and Pallet**

Spill tray and pallet would be placed below the storage tank. The volume of a spill tray must be able to collect 10% of the mercury volume in the tanks above. Spill trays were designed for 35-KG, 1-T and 2-T tank. The pallet was designed only for the 35-KG tank because this tank would be more often to transport than 1-T and 2-T tanks.

The pallet and spill tray for 35-KG tanks were merged and can hold 16 tanks, with 4 × 4 symmetric configurations for safety and convenience handling by forklift (total mass still under 1 tonne). For the 1-T tank, the spill tray was designed to hold eight tanks

with 4 × 2 configuration, identical with guidance by U.S. DOE (Oak Ridge National Laboratory, 2009).

For the 2-T tank, the spill tray was designed to hold four tanks with 2 × 2 configuration for convenient handling, cleaning, and manufacture. The design of the pallet tray is shown in Figure 8, while the design of the spill tray for 1-T and 2-T tanks are shown in Figure 9. The dimension of the spill tray and pallet is showed in Table 6.

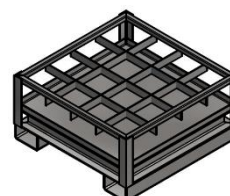

Figure 8. Pallet design for 35-KG tanks

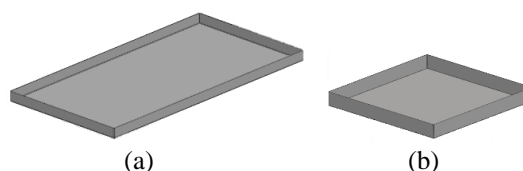

Figure 9. Spill tray design for (a) 1-T and (b) 2-T tanks

Table 6. Spill tray (ST) and pallet (P) dimension

Tank type	Outer length (mm)	Outer width (mm)	Outer height (mm)	Thickness (mm)
ST 35-KG	800	800	40	5
ST 1-T	2450	1250	65	5
ST 2-T	1450	1450	95	5
P 35-KG	800	800	400	-

**Rack**

The rack was designed with two levels and each level can hold two pallets. The dimension of a rack is 2250 mm × 650 mm × 710 mm. The rack design is shown in Figure 10.

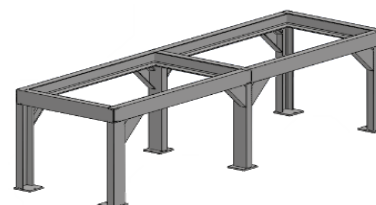

Figure 10. Rack design

**Mechanical Valve and Level Indicator**

The mechanical valve and level indicator are additional accessories to every tank. The mechanical valve was designed to minimize the escaping gas while filling and emptying the tank. Meanwhile, the level indicator was designed to qualitatively and easily detect the mercury level. Mechanical valve and level indicator design are shown in Figure 11 and Figure 12, respectively.

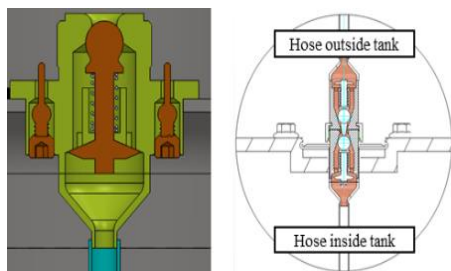

Figure 11. Mechanical valve design

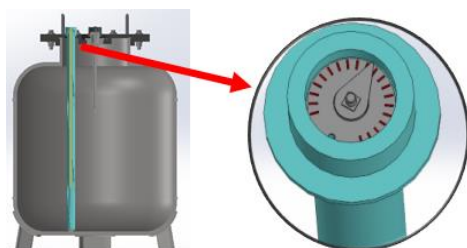

Figure 12. Level indicator design

### Symbol and Label

The classification symbols of mercury are toxic, carcinogenic, teratogenic, and mutagenic, environmental hazards, and empty flask. The symbols are shown in Figure 13. The label which contains the description of mercury is shown in Figure 14.

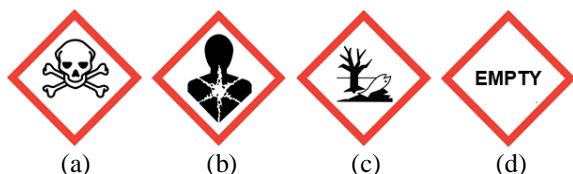

Figure 13. Symbols on mercury storage tank:  
(a) toxic, (b) carcinogenic, teratogenic, and mutagenic, (c) environmental hazard, (d) empty tank

<p><b>Mercury <math>\geq 99.9\%</math></b></p>		<p>Expired date : Purpose of use : Mass inside : Maximum capacity :</p>	<p><b>Material Description:</b> Name : Mercury EC Index Number : 080-001-00-0 EC Number : 231-106-7 CAS # : 7439-97-6 Molecular Formula : Hg Molecular Weight : 200.59 g/mol</p>
<p><b>Handling Information:</b> Avoid contact - get specific instructions before use. First aid measures: <b>Eyes:</b> Get medical aid immediately. Do NOT allow victim to rub eyes or keep eyes closed. Extensive irrigation with water is required (at least 30 minutes). <b>Skin:</b> Get medical aid immediately. Immediately flush skin with plenty of water for at least 15 minutes while removing contaminated clothing and shoes. Wash clothing before reuse. Destroy contaminated shoes. <b>Ingestion:</b> Do not induce vomiting. If victim is conscious and alert, give 2-4 cupsful of milk or water. Never give anything by mouth to an unconscious person. Get medical aid immediately. Wash mouth out with water. <b>Inhalation:</b> Get medical aid immediately. Remove from exposure and move to fresh air immediately. If breathing is difficult, give oxygen. Do NOT use mouth-to-mouth resuscitation. If breathing has ceased apply artificial respiration using oxygen and a suitable mechanical device such as a bag and a mask. <b>Notes to Physician:</b> The concentration of mercury in whole blood is a reasonable measure of the body-burden of mercury and thus is used for monitoring purposes. Treat symptomatically and supportively. Persons with kidney disease, chronic respiratory disease, liver disease, or skin disease may be at increased risk from exposure to this substance. <b>Antidote:</b> The use of d-Penicillamine as a chelating agent should be determined by qualified medical personnel. The use of Dimercaprol or BAL (British Anti-Lewisite) as a chelating agent should be determined by qualified medical personnel.</p>		<p><b>DANGER!</b> Corrosive. This substance has cause adverse reproductive and fetal effects in animals. May be absorbed through intact skin. May cause central nervous system effects. May cause liver and kidney damage. Inhalation of fumes may cause metal-fume fever. Possible sensitizer. Toxic if inhaled. Causes irritation and possible burns by all routes of exposure.</p>	
<p><b>Property of Indonesia Ministry of Environment and Forestry</b></p>		<p><b>Target Organs:</b> Blood, kidneys, central nervous system, liver, brain.</p>	

Figure 14. The sample label that would be attached to a mercury storage tank

### Engineering Drawing

The engineering drawings of storage tanks, spill trays, pallets, and racks were drawn according to criteria and results. The engineering drawings are shown in Figure 15 until Figure 21. The millimeter unit was used to show the length scale.

Figure 15, Figure 16, and Figure 17 show the engineering drawing of the 35-KG tank, 1-T tank, and 2-T tank, respectively. The engineering drawing shows all of the parts of the tank, such as shell, head, neck, bottom, handle, lug, flange, feet, mechanical valve, and level indicator.

Figure 18 shows the engineering drawing of 35-KG tanks and pallet arrangement. Meanwhile, Figure 19 shows the engineering drawing of 35-KG tanks, pallets, and rack arrangement. In addition to the minimum of spill volume, the pallet was also designed with an appropriate additional space, so the tank doesn't fall easily when the pallet was transported. The rack was designed with only two levels and one level can be placed with only two pallets for safety and convenience handling to avoid overload to the rack.

Figure 20 shows the engineering drawing of 1-T tanks and spill tray arrangement. Meanwhile, Figure 21 shows the engineering drawing of 2-T tanks and spill tray arrangement. In addition to the minimum of spill volume, both spill trays were also designed with an appropriate additional space for safety and convenience handling, so the tank can be placed easily on the spill tray.

### CONCLUSION

The conceptual designs and the engineering drawings of the mercury storage tanks (with capacity 35-KG, 1-T, and 2-T) and the arrangements with the attributes (spill tray, pallet, and rack) have been conducted. Several design criteria were used as model development, such as storage capacity, height level, safety factor material, storage temperature, tank life span, and symbols and label.



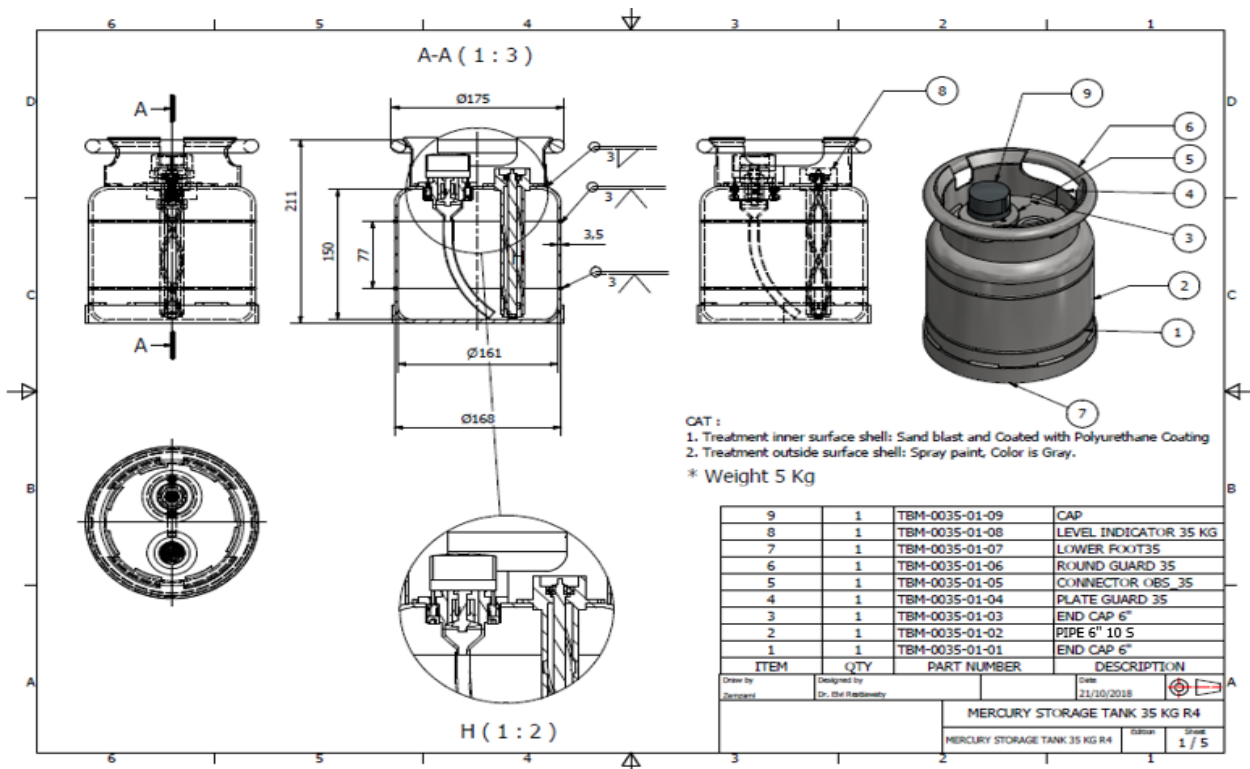

Figure 15. Engineering drawing of the 35-KG tank

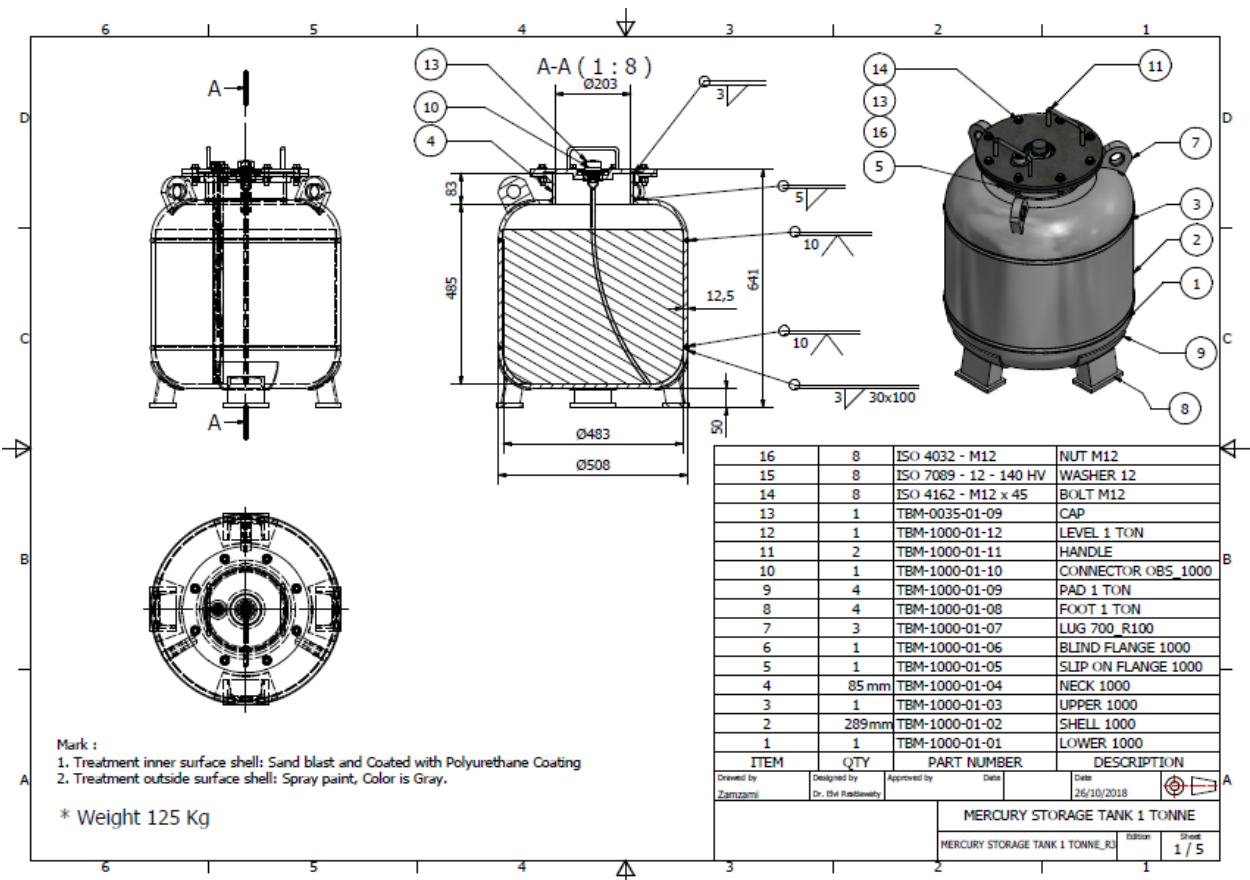

Figure 16. Engineering drawing of the 1-T tank

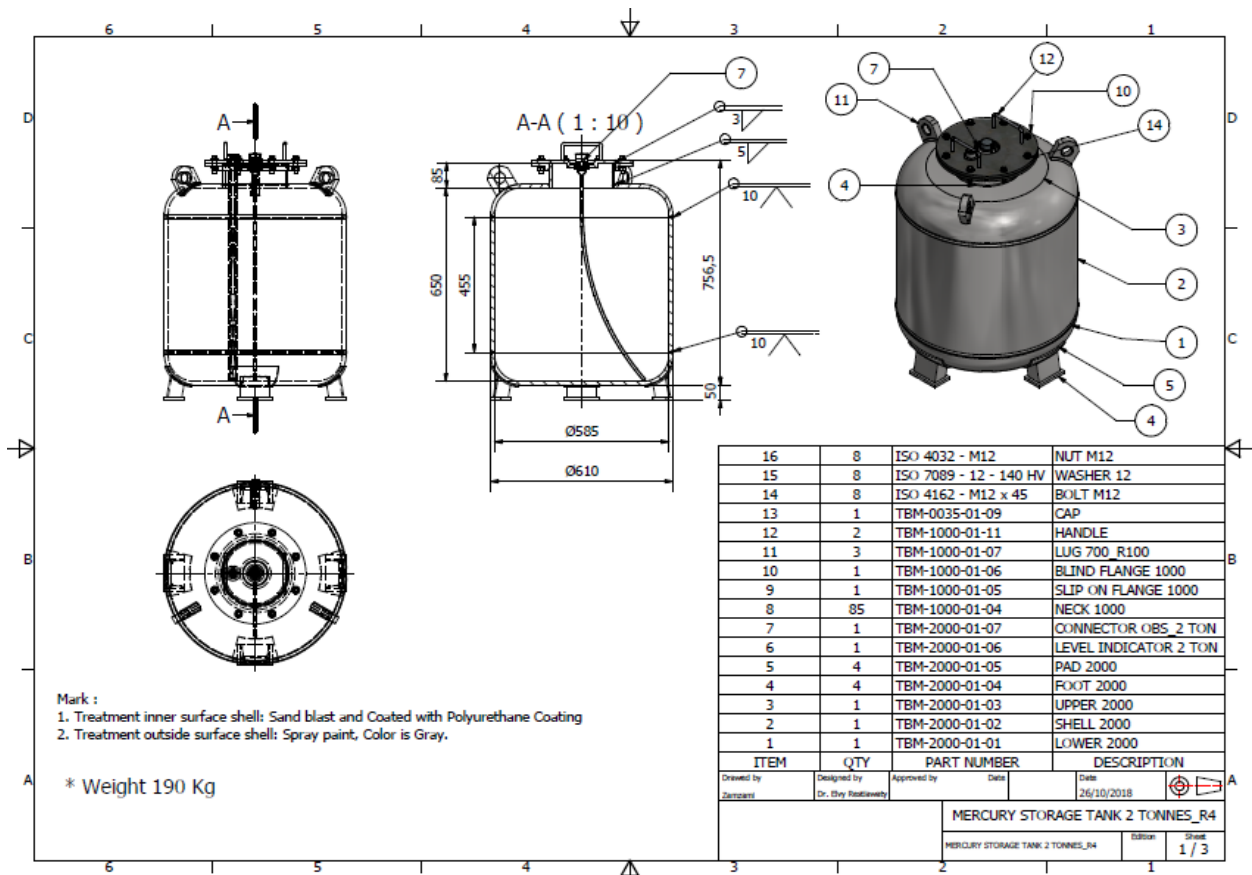

Figure 17. Engineering drawing of the 2-T tank

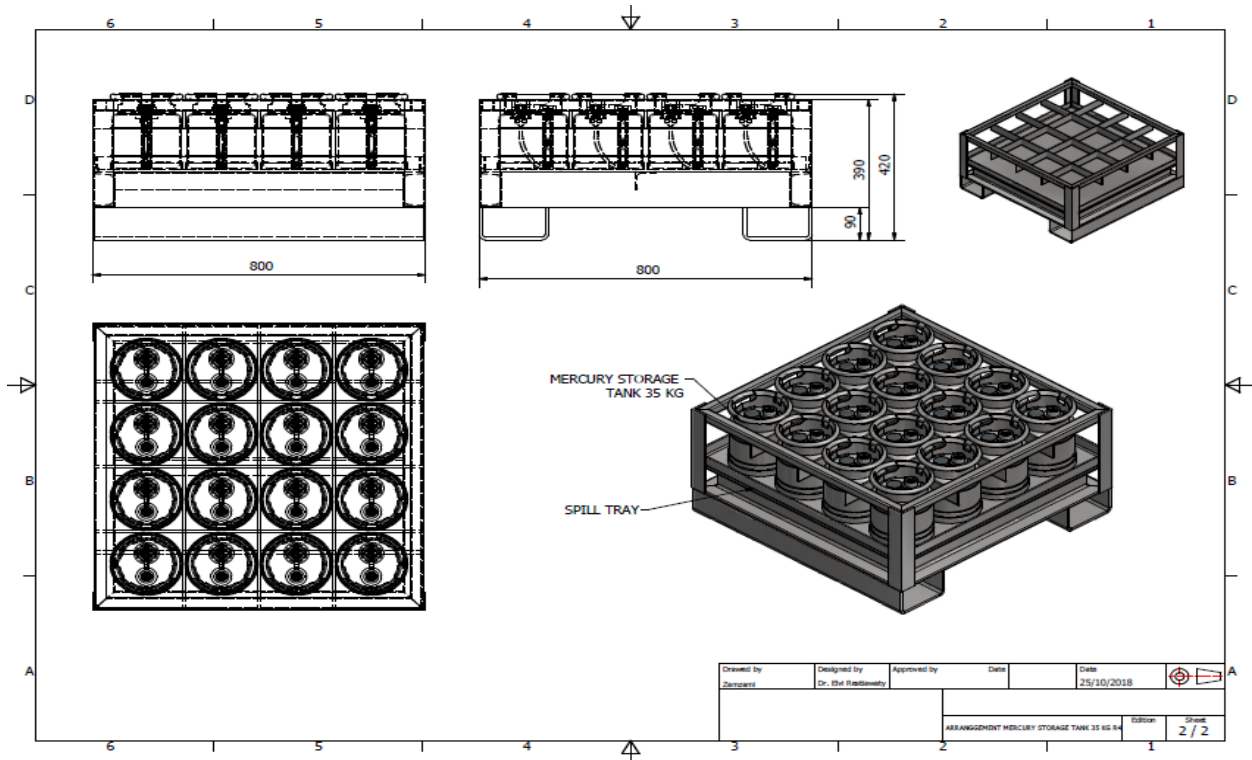

Figure 18. Engineering drawing of 35-KG tanks and pallet arrangement



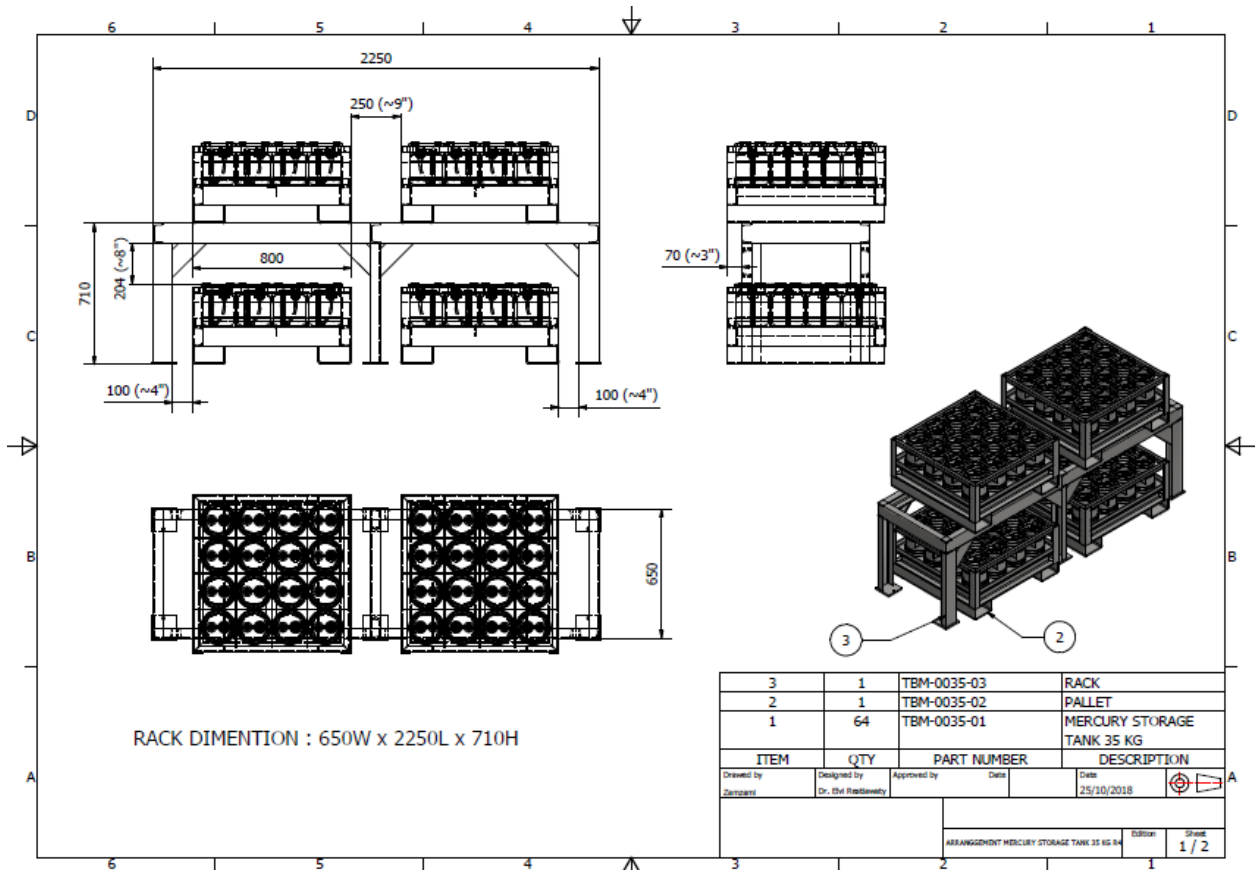

Figure 19. Engineering drawing of 35-KG tanks, pallet, and rack arrangement

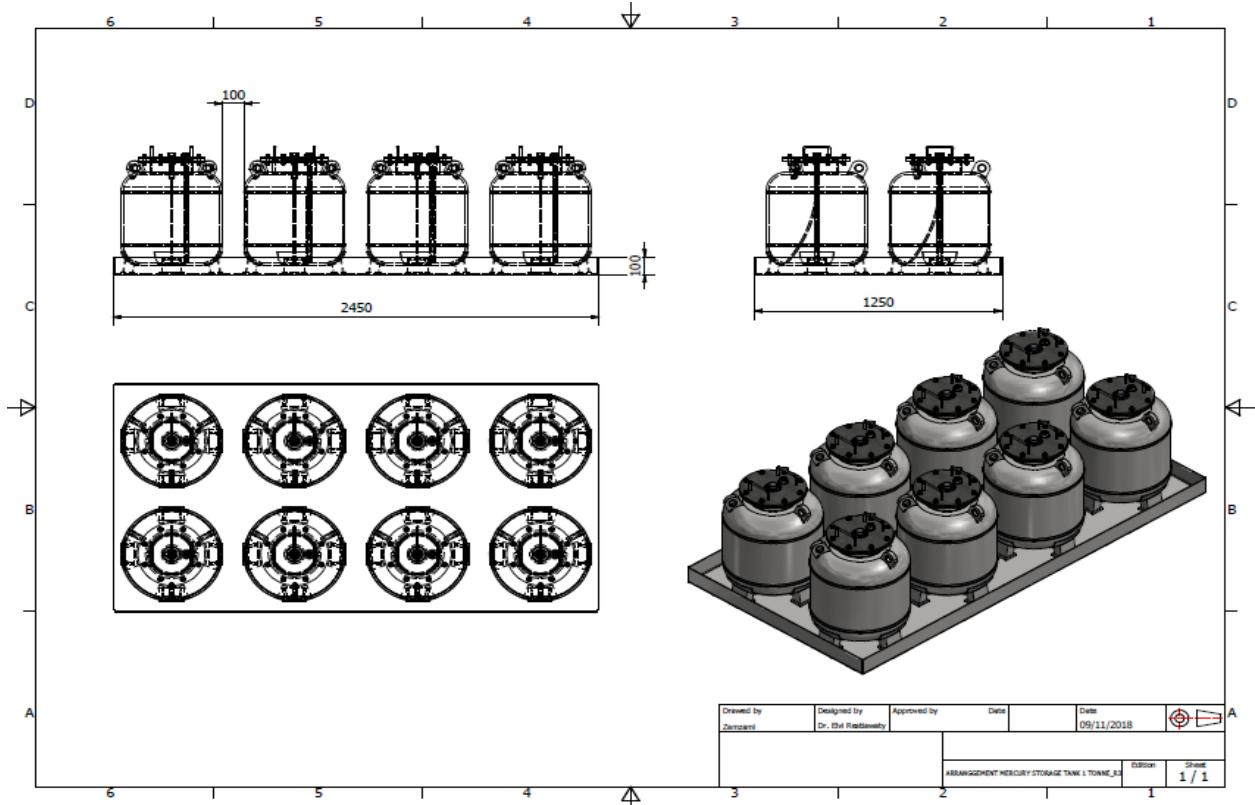

Figure 20. Engineering drawing of 1-T tanks and spill tray arrangement

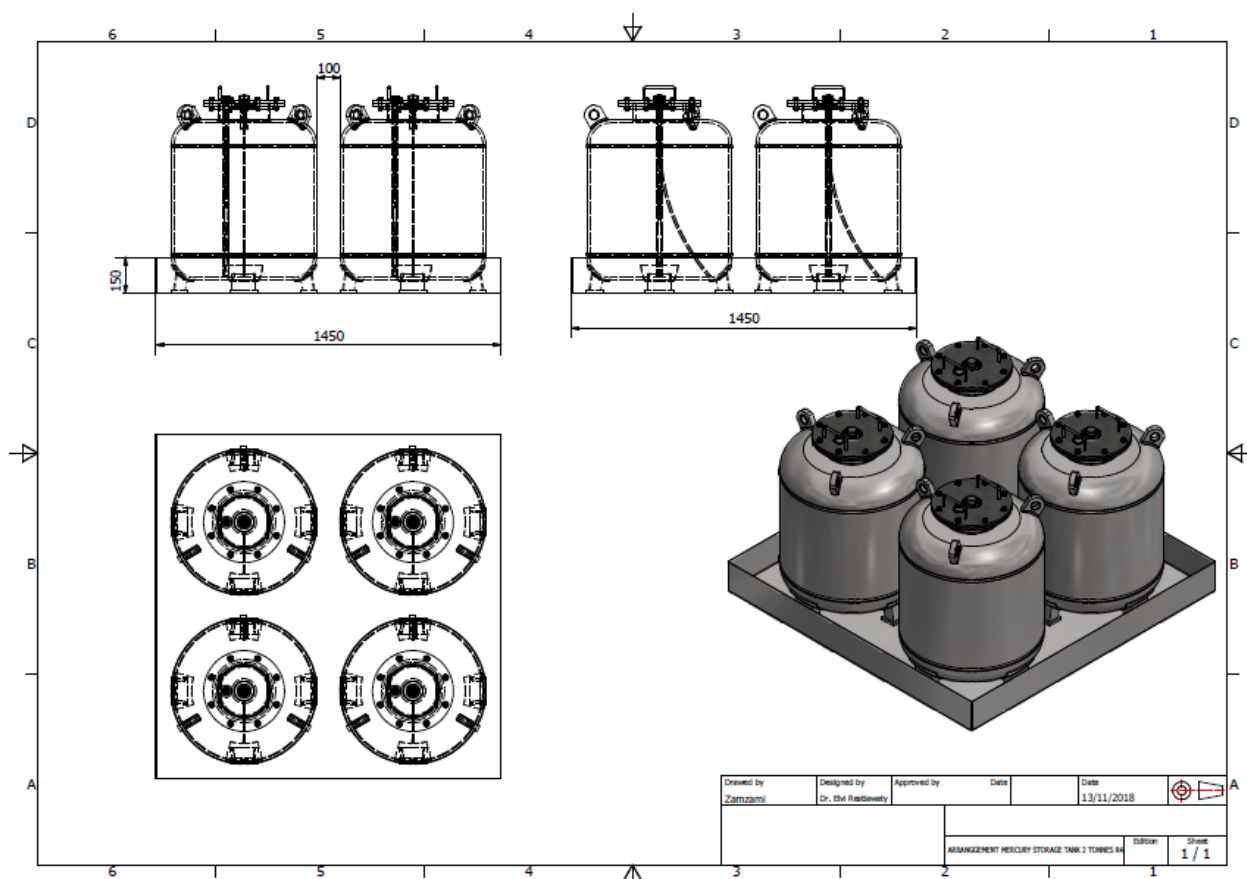

Figure 21. Engineering drawing of 2-T tanks and spill tray arrangement

The 35-KG tanks were specifically designed for temporary storage and transportation via land way, waterway, or airway. Meanwhile, the 1-T and 2-T tanks were specifically designed for 40 years of storage.

#### ACKNOWLEDGMENT

The author would like to thank the ministry of environment and forestry for their support in carrying out the conceptual design of this mercury storage tank.

#### REFERENCES

American Petroleum Institute, (2013), *API 620: Design and Construction of Large, Welded, Low-Pressure Storage Tanks*, API Publishing Services.

American Petroleum Institute, (2013), *API 650: Welded Steel Tanks for Oil Storage*, API Publishing Services.

Broussard, L.A., Hammett-Stabler, C.A., Winecker, R.E., Roper-Miller, J.D., (2002), "The Toxicology of Mercury", *Laboratory Medicine*, Number 8 Volume 33, pp. 614-625.

Carroll, A.J., (2009), *Design of Mercury Storage Containers*, Oak Ridge National Laboratory.

Crowl, D.A., Louvar, J.F., (2011), *Chemical Process Safety: Fundamentals with Applications*, Pearson Education, Inc., USA.

Dewi, K., (2012), Inventory of mercury releases in Indonesia, *BaliFokus*, Denpasar.

Fisher Scientific, (2009), *Material Safety Data Sheet of Mercury*, Fisher Scientific, New Jersey.

Indonesian Ministry of Environment and Forestry, (2008), "Ministerial Regulation of Indonesia Ministry of Environment Number 03 Year 2008 about Procedures for Giving Symbols and Labels of Hazardous and Toxic Materials", Indonesia Ministry of Transportation, Jakarta.

Indonesia Ministry of Transportation, (2004), *Director General Decree of Land Transportation Number SK.725/AJ.302/DRJD/2004 about Organizing the Transport of Hazardous and Toxic Materials on the Road*, Indonesia Ministry of Transportation, Jakarta.

International Air Transport Association, (2006), *IATA Dangerous Good Regulations*, IATA Dangerous Goods Board, Switzerland.

International Maritime Organization, (2006), *IMO International Maritime Dangerous Goods*, International Maritime Organization, London.

Ismawati, Y., (2010), Policy Brief: ASGM in Indonesia, *BaliFokus*, Denpasar.

Kranzlein, P.M., (1959), Corrosion of carbon steel in waste solutions containing mercury, *Metallurgy and Ceramics*, South Carolina, 1959.

Oak Ridge National Laboratory, (2009), “*United States Department of Energy Interim Guidance on Packaging, Transportation, Receipt, Management, and Long-Term Storage of Elemental Mercury*”, U.S. Department of Energy, Washington D.C.

Roberge, P.R., (2008), *Corrosion Engineering Principles and Practice*, 1<sup>st</sup> Ed., McGraw-Hill, New York.

Science for Environment Policy, (2017), *Tackling mercury pollution in the EU and worldwide*, In-depth Report 15 produced for the European Commission, DG Environment by the Science Communication Unit, UWE, Bristol.

Thermo Fisher Scientific, (2019), *Material Safety Data Sheet of Mercury*, Thermo Fisher Scientific, East Midlands.

U.S. Department of Energy, (2010), *Long-Term Management and Storage of Elemental Mercury*, U.S. Department of Energy, Washington D.C.

United Nations Environment Programme, (2013), *Global Mercury Assessment: Sources, Emissions, Releases, and Environmental Transport*, Switzerland.